

# T.D. 5

## Lecture d'une ROM

### PARTIE 1 : Initialisation et commande

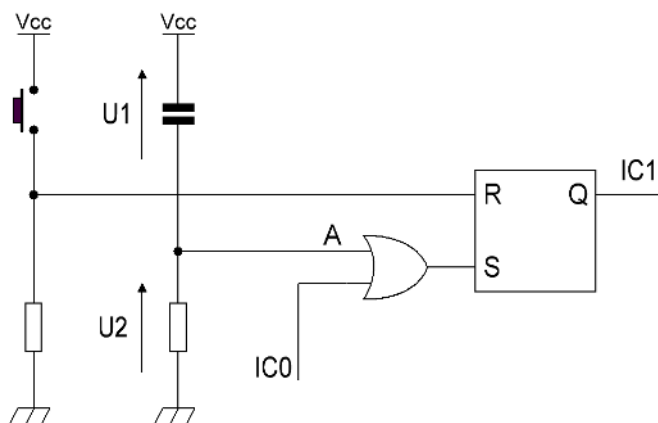

#### Indications :

- Le bouton-poussoir n'est pas pressé lors de la mise sous tension ;
- Bouton-poussoir relâché  $\rightarrow R = 0$  ;
- Bouton-poussoir pressé  $\rightarrow R = 1$  ;
- La tension de seuil est  $V_{cc} / 2$  ;
- Le niveau logique  $A$  considéré par la porte OU est 1 lorsque la tension  $U2$  est supérieure à la tension de seuil et 0 lorsque la tension  $U2$  est inférieure à la tension de seuil.

Évolution de la tension  $U1$  aux bornes du condensateur à la mise sous tension :

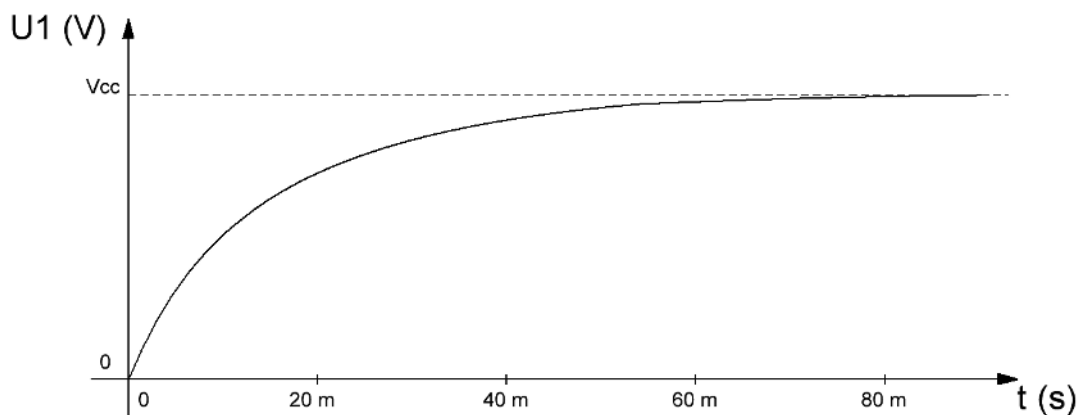

1. Dessinez l'évolution de la tension  $U2$  puis celle du niveau logique  $A$  considéré par la porte OU.
2. Donnez la valeur de l'entrée  $S$  en régime transitoire (au moment la mise sous tension) et en régime permanent (environ 10 ms après la mise sous tension).
3. Si  $IC0$  est au niveau bas à l'allumage, à quelle valeur est initialisée la sortie  $IC1$  ?
4. Une fois en régime permanent et en supposant que la bascule RS soit dans l'état mémoire, comment faire passer la sortie  $IC1$  à 0 quand elle est à 1 ?
5. Une fois en régime permanent et en supposant que la bascule RS soit dans l'état mémoire, comment faire passer la sortie  $IC1$  à 1 quand elle est à 0 ?

## **PARTIE 2 : Les compteurs**

On désire réaliser un compteur **C1** sur 11 bits ( $Q_{10:0}$ ) et un compteur **C2** sur 4 bits modulo 10 ( $Q_{3:0}$ ). Pour **C1**, on dispose de plusieurs **74HCT193**. Pour **C2**, on dispose d'un **74HCT192**. On appelle respectivement  $CK1$  et  $CK2$  les entrées d'horloge de **C1** et de **C2**.

6. À l'aide de la [documentation technique](#) du **74HCT193**, déterminez combien de **74HCT193** sont nécessaires pour réaliser **C1**.
7. Trouvez les autres noms donnés aux entrées  $C3$ ,  $2+$ ,  $1-$  et  $R$ , puis donnez la fonction de chaque entrée-sortie du **74HCT193**.
8. Donnez un schéma de câblage pour **C1** en supposant qu'il compte en boucle.
9. À l'aide du montage de la partie 1 et de la question précédente, remplissez en partie le [document réponse](#) afin de réaliser les conditions suivantes :
  - Les sorties de **C1** doivent être initialisées à 0 lors de la mise sous tension ;
  - **C1** doit commencer à compter après un appui sur le bouton-poussoir ;
  - **C1** doit s'arrêter de compter et garder toutes ses sorties à 0 après avoir atteint sa valeur maximale.
10. Câblez le **74HCT192** sur le [document réponse](#) sachant que **C2** compte uniquement lorsque **C1** compte et qu'il positionne un 0 sur toutes ses sorties quand il ne compte pas. Le **74HCT192** est la version modulo 10 du **74HCT193**.

## **PARTIE 3 : Lecture de la ROM**

On souhaite lire toutes les adresses successives d'une ROM de type **M2716** après un appui sur le bouton-poussoir. On utilisera pour cela le compteur **C1**.

11. En vous aidant de la [documentation technique](#) d'une **M2716**, câblez chaque entrée de la ROM sur le [document réponse](#).

## **PARTIE 4 : Transmission série**

On désire transférer le contenu d'une ROM de type **M2716** via une liaison série RS-232.

Structure d'une trame :

- Un bit de *start* égal à 0 ;
- Huit bits de données ;
- Un bit de *stop* égal à 1 (servant aussi de bit de repos) ;
- Une vitesse de transmission de 9600 bauds.

Exemple d'une trame :

$D = 01101001_2$

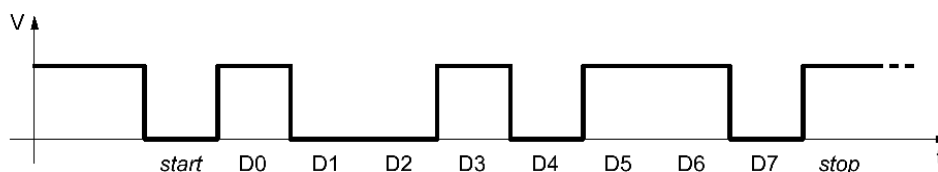

La conversion parallèle-série se fera à l'aide du multiplexeur **MM74C150** (cf. [documentation technique](#)).

12. Que faut-il ajouter en sortie du multiplexeur ?
13. Combien d'entrées de donnée du multiplexeur seront utilisées ?
14. Lorsqu'il n'y a pas d'émission, les entrées *ABCD* du multiplexeur sont nulles. Câblez les entrées de donnée sur le [document réponse](#) afin d'obtenir la trame voulue.
15. Ce sont les sorties de **C2** qui vont servir à piloter le multiplexeur. Terminez le câblage des entrées du multiplexeur.
16. Quelle fréquence doit être présente sur *CK2* ?

L'octet de l'adresse de la ROM doit rester présent en entrée du multiplexeur durant la totalité du transfert de tous ses bits. Une fois transféré, on doit passer à l'octet suivant.

17. À quoi faut-il relier *CK1* ?
18. Combien de temps durera le transfert de toute la mémoire ?

Afin d'économiser le nombre de composants, toutes les portes et les bascules de ce montage seront réalisées à l'aide de portes NON-OU.

19. Donnez le nouveau schéma de câblage.

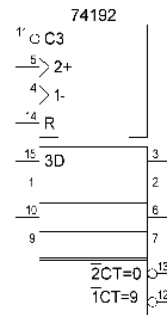
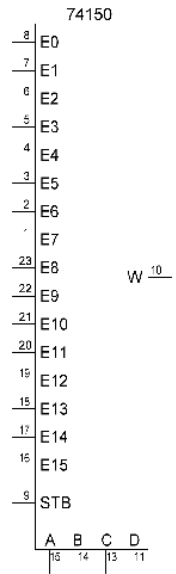
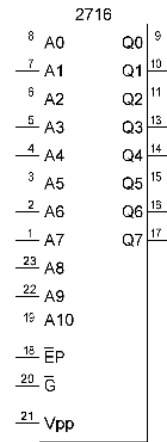
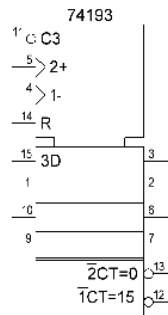
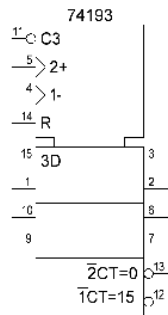
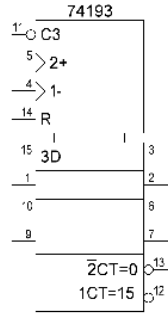
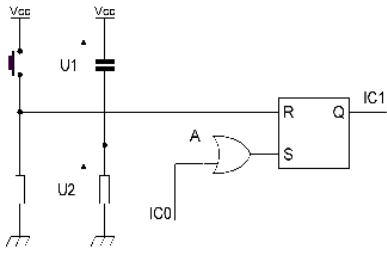

## Presettable synchronous 4-bit binary up/down counter

### 74HC/HCT193

#### FEATURES

- Synchronous reversible 4-bit binary counting
- Asynchronous parallel load
- Asynchronous reset
- Expandable without external logic
- Output capability: standard
- $I_{CC}$  category: MSI

#### GENERAL DESCRIPTION

The 74HC/HCT193 are high-speed Si-gate CMOS devices and are pin compatible with low power Schottky TTL (LSTTL). They are specified in compliance with JEDEC standard no. 7A.

The 74HC/HCT193 are 4-bit synchronous binary up/down counters. Separate up/down clocks,  $CP_U$  and  $CP_D$  respectively, simplify operation. The outputs change state synchronously with the LOW-to-HIGH transition of either clock input. If the  $CP_U$  clock is pulsed while  $CP_D$  is held HIGH, the device will count up. If the  $CP_D$  clock is pulsed while  $CP_U$  is held HIGH, the device will count down. Only one clock input can be held HIGH at any time, or erroneous operation will result. The device can be cleared at any time by the asynchronous master reset input (MR); it may also be loaded in parallel by activating the asynchronous parallel load input ( $\overline{PL}$ ).

The "193" contains four master-slave JK flip-flops with the necessary steering logic to provide the asynchronous reset, load, and synchronous count up and count down functions.

Each flip-flop contains JK feedback from slave to master, such that a LOW-to-HIGH transition on the  $CP_D$  input will decrease the count by one, while a similar transition on the  $CP_U$  input will advance the count by one.

One clock should be held HIGH while counting with the other, otherwise the circuit will either count by two's or not at all, depending on the state of the first flip-flop, which cannot toggle as long as either clock input is LOW. Applications requiring reversible operation must make the reversing decision while the activating clock is HIGH to avoid erroneous counts.

The terminal count up ( $\overline{TC}_U$ ) and terminal count down ( $\overline{TC}_D$ ) outputs are normally HIGH. When the circuit has reached the maximum count state of 15, the next HIGH-to-LOW transition of  $CP_U$  will cause  $\overline{TC}_U$  to go LOW.

$\overline{TC}_U$  will stay LOW until  $CP_U$  goes HIGH again, duplicating the count up clock.

Likewise, the  $\overline{TC}_D$  output will go LOW when the circuit is in the zero state and the  $CP_D$  goes LOW. The terminal count outputs can be used as the clock input signals to the next higher order circuit in a multistage counter, since they duplicate the clock waveforms. Multistage counters will not be fully synchronous, since there is a slight delay time difference added for each stage that is added.

The counter may be preset by the asynchronous parallel load capability of the circuit. Information present on the parallel data inputs ( $D_0$  to  $D_3$ ) is loaded into the counter and appears on the outputs ( $Q_0$  to  $Q_3$ ) regardless of the conditions of the clock inputs when the parallel load ( $\overline{PL}$ ) input is LOW. A HIGH level on the master reset (MR) input will disable the parallel load gates, override both clock inputs and set all outputs ( $Q_0$  to  $Q_3$ ) LOW. If one of the clock inputs is LOW during and after a reset or load operation, the next LOW-to-HIGH transition of that clock will be interpreted as a legitimate signal and will be counted.

Pre-settable synchronous 4-bit binary up/down counter

74HC/HCT193

PIN DESCRIPTION

PIN NO.	SYMBOL	NAME AND FUNCTION
3, 2, 6, 7	Q <sub>0</sub> to Q <sub>3</sub>	flip-flop outputs
4	CP <sub>D</sub>	count down clock input <sup>(1)</sup>
5	CP <sub>U</sub>	count up clock input <sup>(1)</sup>
8	GND	ground (0 V)
11	$\overline{PL}$	asynchronous parallel load input (active LOW)
12	$\overline{TC}_U$	terminal count up (carry) output (active LOW)
13	$\overline{TC}_D$	terminal count down (borrow) output (active LOW)
14	MR	asynchronous master reset input (active HIGH)
15, 1, 10, 9	D <sub>0</sub> to D <sub>3</sub>	data inputs
16	V <sub>CC</sub>	positive supply voltage

Note

1. LOW-to-HIGH, edge triggered

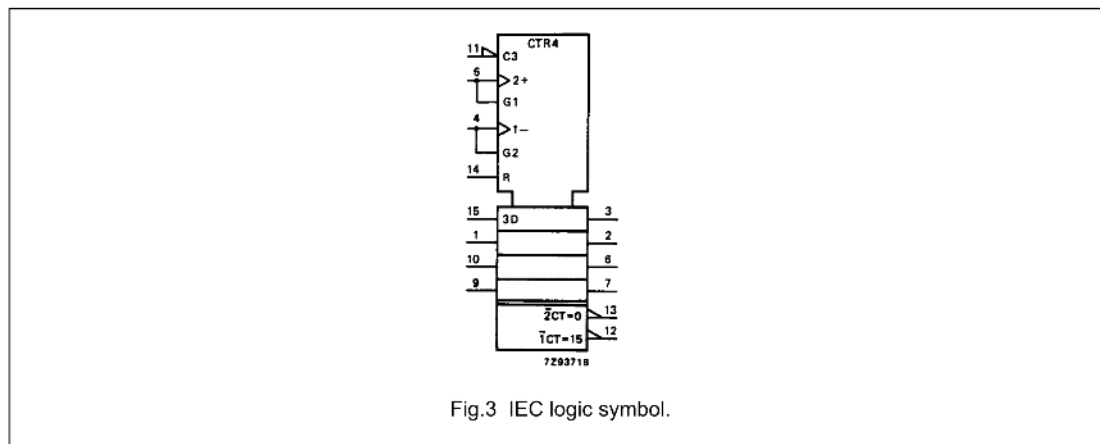
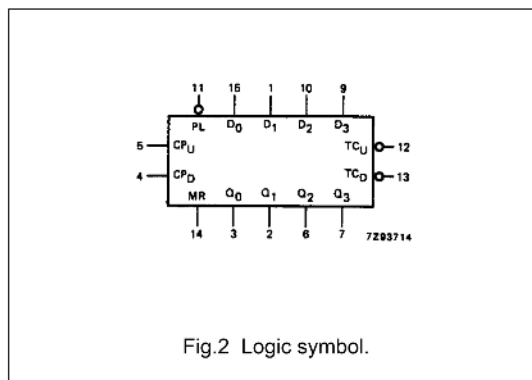
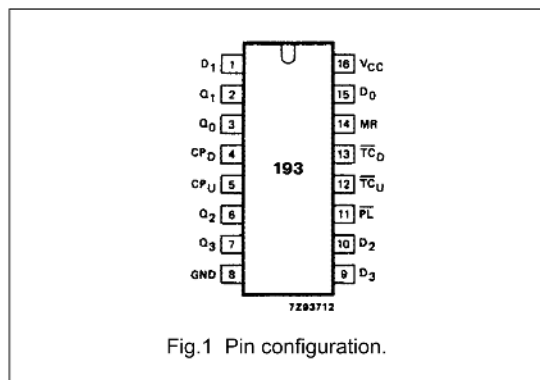

## Presetable synchronous 4-bit binary up/down counter

74HC/HCT193

### FUNCTION TABLE

OPERATING MODE	INPUTS								OUTPUTS					
	MR	$\overline{PL}$	CP <sub>U</sub>	CP <sub>D</sub>	D <sub>0</sub>	D <sub>1</sub>	D <sub>2</sub>	D <sub>3</sub>	Q <sub>0</sub>	Q <sub>1</sub>	Q <sub>2</sub>	Q <sub>3</sub>	$\overline{TC}_U$	$\overline{TC}_D$
reset (clear)	H	X	X	L	X	X	X	X	L	L	L	L	H	L
	H	X	X	H	X	X	X	X	L	L	L	L	H	H
parallel load	L	L	X	L	L	L	L	L	L	L	L	L	H	L
	L	L	X	H	L	L	L	L	L	L	L	L	H	H
	L	L	L	X	H	H	H	H	H	H	H	H	L	H
	L	L	H	X	H	H	H	H	H	H	H	H	H	H
count up	L	H	↑	H	X	X	X	X	count up			H <sup>(2)</sup>	H	
count down	L	H	H	↑	X	X	X	X	count down			H	H <sup>(3)</sup>	

### Notes

- H = HIGH voltage level  
L = LOW voltage level  
X = don't care  
↑ = LOW-to-HIGH clock transition
- $\overline{TC}_U$  = CP<sub>U</sub> at terminal count up (HHHH)
- $\overline{TC}_D$  = CP<sub>D</sub> at terminal count down (LLLL)

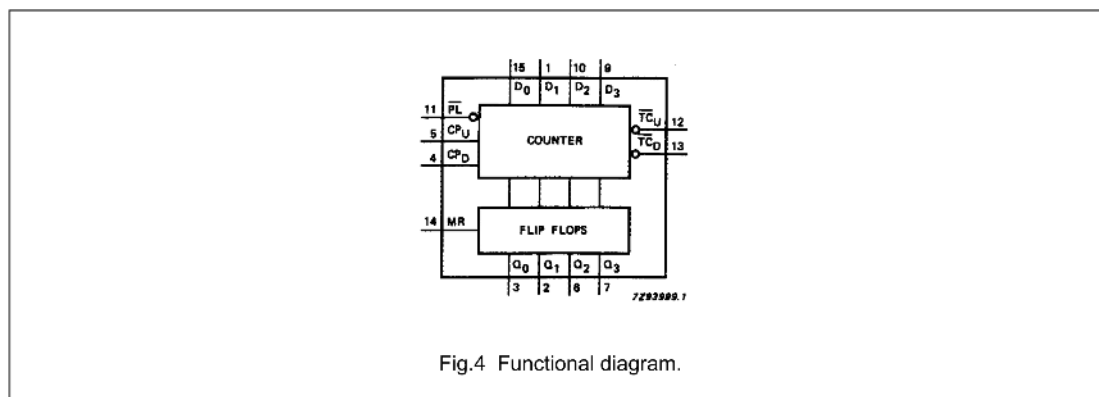

Pre-settable synchronous 4-bit binary up/down counter

74HC/HCT193

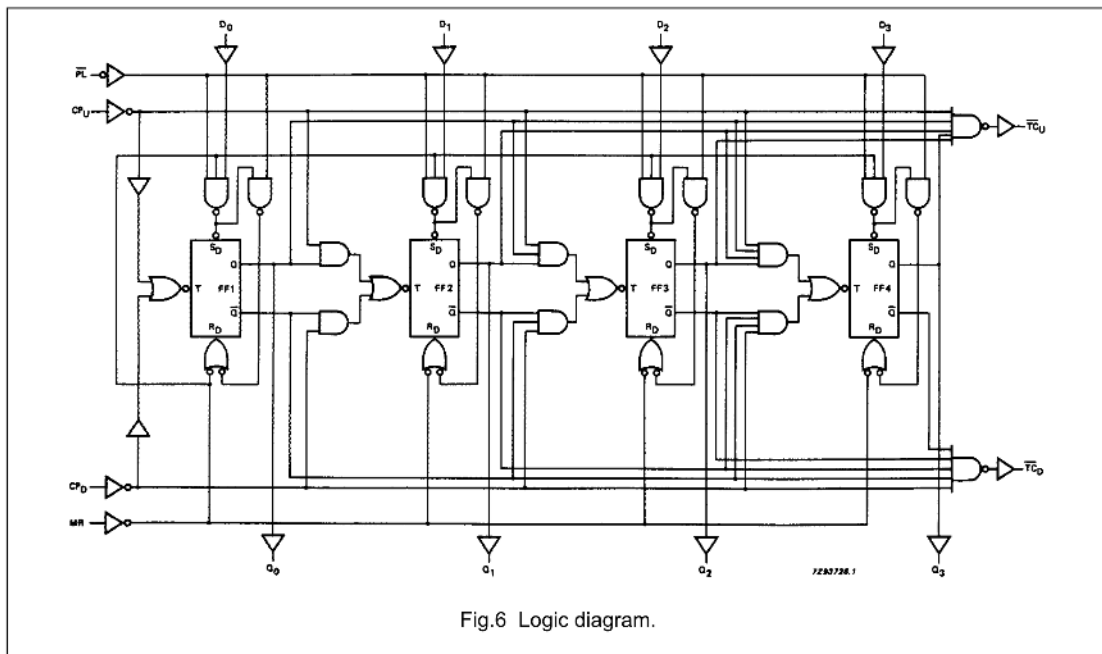
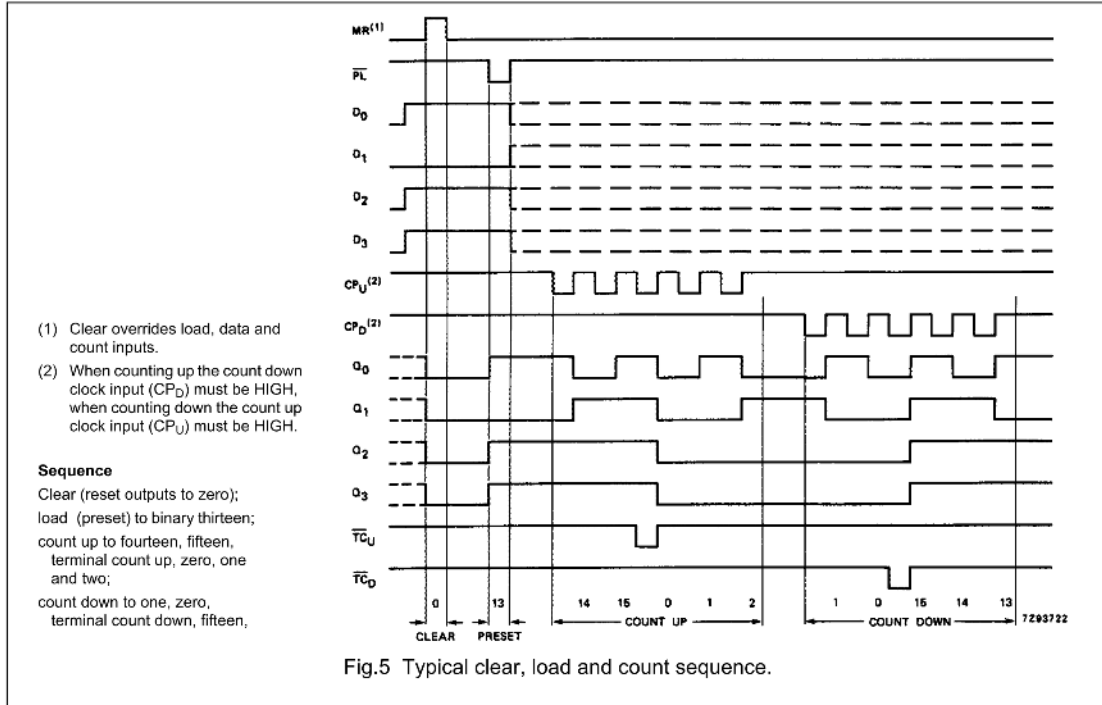



October 1987  
Revised May 2002

# MM74C150 • MM82C19

## 16-Line to 1-Line Multiplexer 3-STATE • 16-Line to 1-Line Multiplexer

### General Description

The MM74C150 and MM82C19 multiplex 16 digital lines to 1 output. A 4-bit address code determines the particular 1-of-16 inputs which is routed to the output. The data is inverted from input to output.

A strobe override places the output of MM74C150 in the logical "1" state and the output of MM82C19 in the high-impedance state.

All inputs are protected from damage due to static discharge by diode clamps to  $V_{CC}$  and GND.

### Features

- Wide supply voltage range: 3.0V to 15V
- Guaranteed noise margin: 1.0V
- High noise immunity:  $0.45 V_{CC}$  (typ.)
- TTL compatibility: Drive 1 TTL Load

### Ordering Code:

Order Number	Package Number	Package Description
MM74C150N	N24A	24-Lead Plastic Dual-In-Line Package (PDIP), JEDEC MS-010, 0.600" Wide
MM82C19N	N24A	24-Lead Plastic Dual-In-Line Package (PDIP), JEDEC MS-010, 0.600" Wide

### Connection Diagram

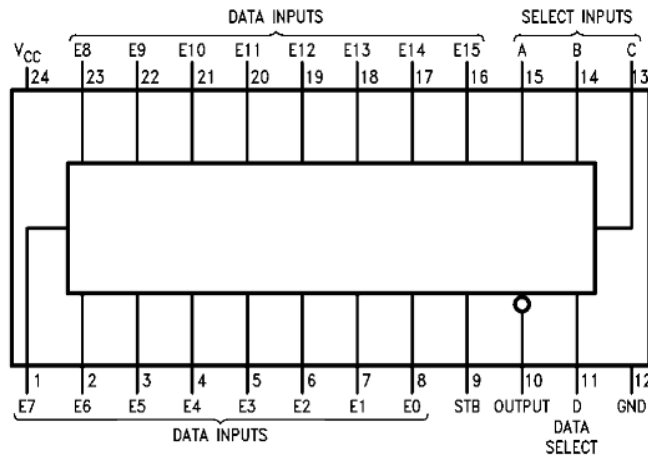

MM74C150 • MM82C19 16-Line to 1-Line Multiplexer 3-STATE • 16-Line to 1-Line Multiplexer

MM74C150 • MM82C19

Truth Table

MM74C150

Inputs																Output						
D	C	B	A	STROBE	E0	E1	E2	E3	E4	E5	E6	E7	E8	E9	E10	E11	E12	E13	E14	E15	W	
X	X	X	X	1	X	X	X	X	X	X	X	X	X	X	X	X	X	X	X	X	X	1 (Note 1)
0	0	0	0	0	0	X	X	X	X	X	X	X	X	X	X	X	X	X	X	X	X	1
0	0	0	0	0	1	X	X	X	X	X	X	X	X	X	X	X	X	X	X	X	X	0
0	0	0	1	0	X	0	X	X	X	X	X	X	X	X	X	X	X	X	X	X	X	1
0	0	0	1	0	X	1	X	X	X	X	X	X	X	X	X	X	X	X	X	X	X	0
0	0	1	0	0	X	X	0	X	X	X	X	X	X	X	X	X	X	X	X	X	X	1
0	0	1	0	0	X	X	1	X	X	X	X	X	X	X	X	X	X	X	X	X	X	0
0	0	1	1	0	X	X	X	0	X	X	X	X	X	X	X	X	X	X	X	X	X	1
0	0	1	1	0	X	X	X	1	X	X	X	X	X	X	X	X	X	X	X	X	X	0
0	1	0	0	0	X	X	X	X	0	X	X	X	X	X	X	X	X	X	X	X	X	1
0	1	0	0	0	X	X	X	X	1	X	X	X	X	X	X	X	X	X	X	X	X	0
0	1	0	1	0	X	X	X	X	X	0	X	X	X	X	X	X	X	X	X	X	X	1
0	1	0	1	0	X	X	X	X	X	1	X	X	X	X	X	X	X	X	X	X	X	0
0	1	1	0	0	X	X	X	X	X	X	0	X	X	X	X	X	X	X	X	X	X	1
0	1	1	0	0	X	X	X	X	X	X	1	X	X	X	X	X	X	X	X	X	X	0
0	1	1	1	0	X	X	X	X	X	X	0	X	X	X	X	X	X	X	X	X	X	1
0	1	1	1	0	X	X	X	X	X	X	1	X	X	X	X	X	X	X	X	X	X	0
1	0	0	0	0	X	X	X	X	X	X	X	0	X	X	X	X	X	X	X	X	X	1
1	0	0	0	0	X	X	X	X	X	X	X	1	X	X	X	X	X	X	X	X	X	0
1	0	0	1	0	X	X	X	X	X	X	X	X	0	X	X	X	X	X	X	X	X	1
1	0	0	1	0	X	X	X	X	X	X	X	X	1	X	X	X	X	X	X	X	X	0
1	0	1	0	0	X	X	X	X	X	X	X	X	X	0	X	X	X	X	X	X	X	1
1	0	1	0	0	X	X	X	X	X	X	X	X	X	1	X	X	X	X	X	X	X	0
1	0	1	1	0	X	X	X	X	X	X	X	X	X	X	X	0	X	X	X	X	X	1
1	0	1	1	0	X	X	X	X	X	X	X	X	X	X	X	1	X	X	X	X	X	0
1	1	0	0	0	X	X	X	X	X	X	X	X	X	X	X	X	0	X	X	X	X	1
1	1	0	0	0	X	X	X	X	X	X	X	X	X	X	X	X	1	X	X	X	X	0
1	1	0	1	0	X	X	X	X	X	X	X	X	X	X	X	X	X	0	X	X	X	1
1	1	0	1	0	X	X	X	X	X	X	X	X	X	X	X	X	X	1	X	X	X	0
1	1	1	0	0	X	X	X	X	X	X	X	X	X	X	X	X	X	X	1	X	X	0
1	1	1	0	0	X	X	X	X	X	X	X	X	X	X	X	X	X	X	1	X	X	0
1	1	1	1	0	X	X	X	X	X	X	X	X	X	X	X	X	X	X	X	1	X	0
1	1	1	1	0	X	X	X	X	X	X	X	X	X	X	X	X	X	X	X	1	X	0
1	1	1	1	1	0	X	X	X	X	X	X	X	X	X	X	X	X	X	X	X	X	0
1	1	1	1	1	0	X	X	X	X	X	X	X	X	X	X	X	X	X	X	X	X	1

Note 1: For MM72C19/MM82C19 this would be Hi-Z, everything else is the same.

## NMOS 16K (2K x 8) UV EPROM

- 2048 x 8 ORGANIZATION
- 525mW Max ACTIVE POWER, 132mW Max STANDBY POWER
- ACCESS TIME:
  - M2716-1 is 350ns
  - M2716 is 450ns
- SINGLE 5V SUPPLY VOLTAGE
- STATIC-NO CLOCKS REQUIRED
- INPUTS and OUTPUTS TTL COMPATIBLE DURING BOTH READ and PROGRAM MODES
- THREE-STATE OUTPUT with TIED-OR-CAPABILITY
- EXTENDED TEMPERATURE RANGE
- PROGRAMMING VOLTAGE: 25V

**DESCRIPTION**

The M2716 is a 16,384 bit UV erasable and electrically programmable memory EPROM, ideally suited for applications where fast turn around and pattern experimentation are important requirements.

The M2716 is housed in a 24 pin Window Ceramic Frit-Seal Dual-in-Line package. The transparent lid allows the user to expose the chip to ultraviolet light to erase the bit pattern. A new pattern can then be written to the device by following the programming procedure.

**Table 1. Signal Names**

A0 - A10	Address Inputs
Q0 - Q7	Data Outputs
$\bar{E}P$	Chip Enable / Program
$\bar{G}$	Output Enable
V <sub>PP</sub>	Program Supply
V <sub>CC</sub>	Supply Voltage
V <sub>SS</sub>	Ground

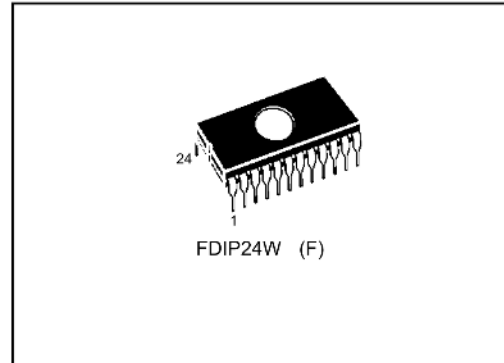
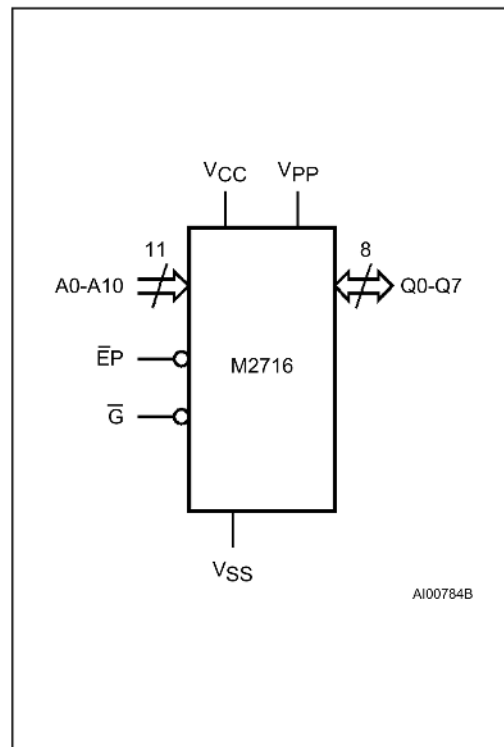
**Figure 1. Logic Diagram**

**M2716****Table 2. Absolute Maximum Ratings**

Symbol	Parameter	Value	Unit
$T_A$	Ambient Operating Temperature grade 1 grade 6	0 to 70 -40 to 85	°C
$T_{BIAS}$	Temperature Under Bias grade 1 grade 6	-10 to 80 -50 to 95	°C
$T_{STG}$	Storage Temperature	-65 to 125	°C
$V_{CC}$	Supply Voltage	-0.3 to 6	V
$V_{IO}$	Input or Output Voltages	-0.3 to 6	V
$V_{PP}$	Program Supply	-0.3 to 26.5	V
$P_D$	Power Dissipation	1.5	W

**Note:** Except for the rating "Operating Temperature Range", stresses above those listed in the Table "Absolute Maximum Ratings" may cause permanent damage to the device. These are stress ratings only and operation of the device at these or any other conditions above those indicated in the Operating sections of this specification is not implied. Exposure to Absolute Maximum Rating conditions for extended periods may affect device reliability. Refer also to the SGS-THOMSON SURE Program and other relevant quality documents.

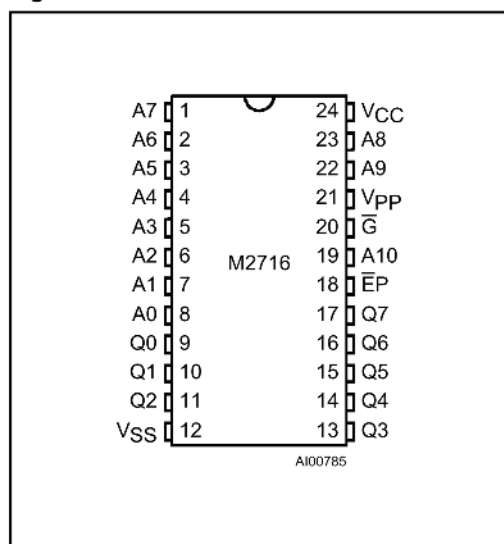
**Figure 2. DIP Pin Connections****DEVICE OPERATION**

The M2716 has 3 modes of operation in the normal system environment. These are shown in Table 3.

**Read Mode.** The M2716 read operation requires that  $\bar{G} = V_{IL}$ ,  $\bar{EP} = V_{IL}$  and that addresses A0-A10 have been stabilized. Valid data will appear on the output pins after time  $t_{AVQV}$ ,  $t_{GLQV}$  or  $t_{ELQV}$  (see Switching Time Waveforms) depending on which is limiting.

**Deselect Mode.** The M2716 is deselected by making  $\bar{G} = V_{IH}$ . This mode is independent of  $\bar{EP}$  and the condition of the addresses. The outputs are Hi-Z when  $\bar{G} = V_{IH}$ . This allows tied-OR of 2 or more M2716's for memory expansion.

**Standby Mode (Power Down).** The M2716 may be powered down to the standby mode by making  $\bar{EP} = V_{IH}$ . This is independent of  $\bar{G}$  and automatically puts the outputs in the Hi-Z state. The power is reduced to 25% (132 mW max) of the normal operating power.  $V_{CC}$  and  $V_{PP}$  must be maintained at 5V. Access time at power up remains either  $t_{AVQV}$  or  $t_{ELQV}$  (see Switching Time Waveforms).

**Programming**

The M2716 is shipped from SGS-THOMSON completely erased. All bits will be at "1" level (output high) in this initial state and after any full erasure. Table 3 shows the 3 programming modes.

**Program Mode.** The M2716 is programmed by introducing "0"s into the desired locations. This is done 8 bits (a byte) at a time. Any individual address, sequential addresses, or addresses chosen at random may be programmed. Any or all of the 8 bits associated with an address location may be programmed with a single program pulse applied to the  $\bar{EP}$  pin. All input voltage levels including the program pulse on chip enable are TTL compatible.

The programming sequence is: with  $V_{PP} = 25V$ ,  $V_{CC} = 5V$ ,  $\bar{G} = V_{IH}$  and  $\bar{EP} = V_{IL}$ , an address is selected and the desired data word is applied to the output pins ( $V_{IL} = "0"$  and  $V_{IH} = "1"$  for both address and data). After the address and data signals are stable the program pin is pulsed from  $V_{IL}$  to  $V_{IH}$  with a

**DEVICE OPERATION** (cont'd)

pulse width between 45ms and 55ms. Multiple pulses are not needed but will not cause device damage. No pins should be left open. A high level ( $V_{IH}$  or higher) must not be maintained longer than  $t_{PHPL}$  (max) on the program pin during programming. M2716's may be programmed in parallel in this mode.

**Program Verify Mode.** The programming of the M2716 may be verified either one byte at a time during the programming (as shown in Figure 6) or by reading all of the bytes out at the end of the programming sequence. This can be done with  $V_{PP} = 25V$  or  $5V$  in either case.  $V_{PP}$  must be at  $5V$  for all operating modes and can be maintained at  $25V$  for all programming modes.

**Program Inhibit Mode.** The program inhibit mode allows several M2716's to be programmed simultaneously with different data for each one by controlling which ones receive the program pulse. All similar inputs of the M2716 may be paralleled. Pulsing the program pin (from  $V_{IL}$  to  $V_{IH}$ ) will program a unit while inhibiting the program pulse to a unit will keep it from being programmed and keeping  $\bar{G} = V_{IH}$  will put its outputs in the Hi-Z state.

**ERASURE OPERATION**

The M2716 is erased by exposure to high intensity ultraviolet light through the transparent window. This exposure discharges the floating gate to its initial state through induced photo current. It is recommended that the M2716 be kept out of direct sunlight. The UV content of sunlight may cause a partial erasure of some bits in a relatively short period of time.

An ultraviolet source of  $2537 \text{ \AA}$  yielding a total integrated dosage of  $15 \text{ watt-seconds/cm}^2$  power rating is used. The M2716 to be erased should be placed 1 inch away from the lamp and no filters should be used.

An erasure system should be calibrated periodically. The erasure time is increased by the square of the distance (if the distance is doubled the erasure time goes up by a factor of 4). Lamps lose intensity as they age, it is therefore important to periodically check that the UV system is in good order.

This will ensure that the EPROMs are being completely erased. Incomplete erasure will cause symptoms that can be misleading. Programmers, components, and system designs have been erroneously suspected when incomplete erasure was the basic problem.

**Table 3. Operating Modes**

Mode	$\bar{EP}$	$\bar{G}$	$V_{PP}$	Q0 - Q7
Read	$V_{IL}$	$V_{IL}$	$V_{CC}$	Data Out
Program	$V_{IH}$ Pulse	$V_{IH}$	$V_{PP}$	Data In
Verify	$V_{IL}$	$V_{IL}$	$V_{PP}$ or $V_{CC}$	Data Out
Program Inhibit	$V_{IL}$	$V_{IH}$	$V_{PP}$	Hi-Z
Deselect	X	$V_{IH}$	$V_{CC}$	Hi-Z
Standby	$V_{IH}$	X	$V_{CC}$	Hi-Z

Note: X =  $V_{IH}$  or  $V_{IL}$ .