

Additional Exam S1

Computer Architecture

Duration: 45 min.

Last name: First name: Group:

Write answers only on the worksheet.

Do not show any calculation unless you are explicitly asked.

Do not use red ink.

Exercise 1 (2 points)

Convert the following numbers from the source form into the destination form. Do not write down the result in a fraction or a power form (e.g. write down 0.25 and not $\frac{1}{4}$ or 2^{-2}).

Number to Convert	Source Form	Destination Form	Result
110011001.01001	Binary	Decimal	
CD.48	Hexadecimal	Decimal	
42	Base 8	Base 6	
11100110101.100111	Binary	Hexadecimal	

Exercise 2 (3 points)

Perform the following 8-bit binary operations (the two operands and the result are 8 bits wide). Then, convert the result into unsigned and signed decimal values. If an overflow occurs, write down 'ERROR' instead of the decimal value.

Operation	Binary Result	Decimal Value	
		Unsigned	Signed
11100111 + 00011001			
11011010 - 10001001			
01110111 - 11111111			

Exercise 3 (3 points)

We want to simplify the following circuit diagram:

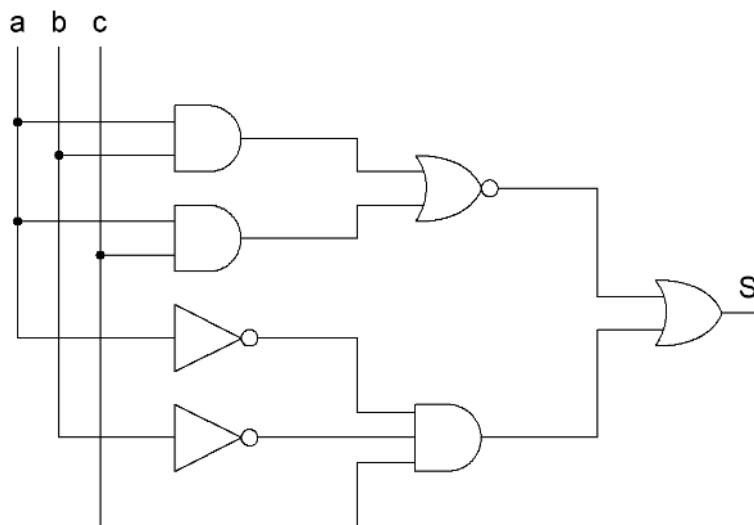

1. Without any simplifications, give the S output in terms of a , b and c .

$S =$

2. Simplify the expression of S by using the algebraic method. **Show all calculations.**

3. From the simplified expression, draw a new circuit diagram by using three NOT gates, one AND gate and one OR gate.

Exercise 4 (2 points)

Complete the Karnaugh maps below (circles included) and give the most simplified expressions for X and Y . No points will be given to an expression if its Karnaugh map is wrong.

		CD			
		00	01	11	10
AB	X				
	00	1	0	1	1
	01	1	0	0	1
	11	0	0	1	1
10	1	0	0	1	

$X =$

		CD			
		00	01	11	10
AB	Y				
	00	1	0	0	1
	01	0	0	1	1
	11	0	0	1	1
10	1	0	0	1	

$Y =$

Feel free to use the blank space below if you need to: