

ALGO
QCM

1. L'implémentation d'une liste récursive sous la forme d'un tableau d'éléments, est ?
 - a) statique
 - b) chaînée
 - c) contiguë
 - d) dynamique

2. L'implémentation sous forme de liste chaînée est ?
 - a) statique
 - b) extatique
 - c) contiguë
 - d) dynamique

3. L'implémentation d'une file sous la forme d'une liste chaînée, n'est pas possible ?
 - a) faux
 - b) vrai

4. Une pile est une structure intrinsèquement ?
 - (a) Récursive
 - (b) Itérative
 - c) Répétitive
 - (d) Alternative

5. Une file est une structure ?
 - a) LIFO
 - b) PIPO
 - c) FIFO
 - d) FILO

6. Que représentent opération1 et opération2 dans l'axiome suivant (dans lequel e est un élément et x une pile) ?
opération1(opération2 (e,x)) = x
 - a) opération1 = sommet, opération2 = dépiler
 - b) opération1 = dépiler, opération2 = sommet
 - c) opération1 = sommet, opération2 = empiler
 - d) opération1 = dépiler, opération2 = empiler

7. Que représentent x , opération1 et opération2 dans l'axiome suivant (dans lequel e est un Élément) ?
 $\text{est-vide}(x) = \text{faux} \Rightarrow \text{opération1}(\text{opération2}(x,e)) = \text{opération2}(\text{opération1}(x),e)$
- (A) x est une File, opération1 = enfiler, opération2 = défiler
 - (B) x est une Pile, opération1 = dépiler, opération2 = empiler
 - (C) x est une File, opération1 = défiler, opération2 = enfiler
 - (D) x est une Pile, opération1 = ajouter, opération2 = empiler
8. L'important dans les ensembles c'est ?
- (A) la position d'un élément dans un ensemble
 - (B) la place d'un élément dans un ensemble
 - (C) l'appartenance d'un élément à un ensemble
 - (D) l'ordre d'un élément dans un ensemble
9. Quelle opération permet de récupérer le nombre d'occurrences d'un élément dans un multi-ensemble ?
- (A) count
 - (B) compte
 - (C) occ
 - (D) card
 - (E) nboccurrences
10. Un élément ne peut pas être présent plusieurs fois dans un ensemble ?
- (A) faux
 - (B) vrai



QCM 12

lundi 6 décembre 2021

Question 11

$\sum_{k=1}^n 2^k$ est égale à

- $2^n - 1$
- 2^n
- $2^{n+1} - 1$
- $2^{n+1} - 2$
- Aucune des autres réponses

Question 12

Soit (u_n) la suite définie par $u_0 = 4$ et, pour tout $n \in \mathbb{N}$, $u_{n+1} = 2u_n - 5$. Alors,

- La suite $(v_n) = (u_n - 5)$ est une suite géométrique.
- La suite $(w_n) = (u_n + 5)$ est une suite géométrique.
- La suite $(v_n) = (u_n - 5)$ est une suite arithmétique.
- La suite $(w_n) = (u_n + 5)$ est une suite arithmétique.
- Aucune des autres réponses

Question 13

Cochez la(les) bonne(s) réponse(s)

- Une suite strictement croissante tend vers $+\infty$.
- Une suite qui tend vers $+\infty$ est croissante.
- Une suite bornée est convergente.
- Une suite non majorée tend vers $+\infty$.
- Aucune des autres réponses

Question 14

Soit (u_n) une suite réelle telle que $\forall n \in \mathbb{N}, u_n \geq 6$. On sait que

- a) Si (u_n) est croissante alors (u_n) converge.
- b) Si (u_n) est décroissante alors (u_n) converge.
- c) (u_n) est majorée.
- d) (u_n) est minorée.
- e) Aucune des autres réponses

Question 15

Considérons une suite (u_n) telle que $\forall n \in \mathbb{N}, u_n \leq \frac{1}{n^2 + 1}$.

Alors,

- a) (u_n) converge vers 0. *→ seulement si $u_n > 0$*
- b) (u_n) est majorée. *← c'est vrai*
- c) (u_n) est strictement décroissante.
- d) Aucune des autres réponses

Question 16

Soient (u_n) et (v_n) deux suites. On a :

- a) Si (u_n) et (v_n) convergent alors $(u_n + v_n)$ converge.
- b) Si (u_n) et (v_n) divergent alors $(u_n + v_n)$ diverge.
- c) Si $(u_n) = (\ln(n))$ alors (u_n) converge.
- d) Si $\lim_{n \rightarrow +\infty} u_n = -3$ alors $\lim_{n \rightarrow +\infty} |u_n| = 3$.
- e) Aucune des autres réponses

Question 17

Cochez la(les) bonne(s) réponse(s)

- a) Une suite croissante est toujours majorée.
- b) Une suite croissante est toujours minorée.
- c) Une suite croissante est toujours convergente.
- d) Aucune des autres réponses

Question 18

Soit (u_n) une suite réelle. On dit que (u_n) est bornée si et seulement si

- A $\forall n \in \mathbb{N}, \exists M \in \mathbb{R}$ tel que $|u_n| \leq M$
- B $\exists (M, m) \in \mathbb{R}^2$ tel que $\forall n \in \mathbb{N}, m \leq u_n \leq M$
- C $\exists M \in \mathbb{R}$ tel que $\forall n \in \mathbb{N}, |u_n| \leq M$
- D Aucune des autres réponses

Question 19

On considère la suite (u_n) définie pour tout $n \in \mathbb{N}$ par $u_n = 2 \times q^n$ où $q \in \mathbb{R}$. On a

- A Si $|q| < 1$ alors $\lim_{n \rightarrow +\infty} u_n = 0$
- B Si $q > 1$ alors $\lim_{n \rightarrow +\infty} u_n = 0$
- C Si $q > 1$ alors $\lim_{n \rightarrow +\infty} u_n = +\infty$
- D Si $q \geq 1$ alors $\lim_{n \rightarrow +\infty} u_n = +\infty$
- E Aucune des autres réponses

Question 20

Soit $(a, b) \in \mathbb{N}^2$ non nuls. On a

- A $a \wedge b = 5 \implies \exists (u, v) \in \mathbb{Z}^2$ tel que $au + bv = 5$
- B $\exists (u, v) \in \mathbb{Z}^2$ tel que $au + bv = 5 \implies a \wedge b = 5$
- C $a \wedge b = 1 \implies \exists! (u, v) \in \mathbb{Z}^2$ tel que $au + bv = 1$
- D $\exists (u, v) \in \mathbb{Z}^2$ tel que $au + bv = 1 \implies a \wedge b = 1$
- E Aucune des autres réponses

CIE S1 MCQ 6/12/21 (Graph12, Graph13)

Graph 12:

21. This graph is a _____.

- A table chart
- B column graph
- C histogram
- D waffle chart

22. In the graph, the icons represent _____.

- A electric powered vehicles
- B vehicles
- C CO2 emissions
- D None of the above

23. Which of the following is an appropriate conclusion derived from this graph?

- A Most of the CO2 emissions in the US is due to passenger cars and SUVs.
- B The environmental and financial costs are relatively lower for electric and hybrid cars in comparison to gas-powered vehicles.
- C Gas-powered cars are going to be phased out quite soon in the US.
- D It will be several decades to have a significant effect on greenhouse gases.

24. Which of the following is the truest?

- A Electric vehicles are projected to make up for more than half of the sales by 2035.
- B Currently fewer than 1 percent of the cars are electric.
- C All vehicles will be electric by 2050.
- D General Motors has promised to end gasoline-powered vehicles completely.

25. Which of the following is not true?

A) Currently most of the cars in the US run on gasoline.

? B) When electric vehicles are expected to make up 60 percent of new sales in the US, most of the vehicles on road will still run on gasoline.

→ C) Currently the electric and hybrid cars have a much higher lifespan in the US.

D) It is projected that by 2035, about 13 percent of vehicles on the road would be electric.

Graph 13:

26. Which statement best describes the topic of graph 13?

A) The United States of America.

B) Increasing and decreasing income. ←

C) U.S. sales as a gross domestic product.

D) Convenience food sales and prosperity.

E) Wealth in high, middle and lower income families. ←

27. According to graph 13, which country saw the largest increase in fast food sales?

A) Greece

B) Argentina

C) The United States of America

D) Morocco

E) The Philippines

28. According to the graph 13, which of these statements is the truest?

A) Lower middle income countries saw a decrease in fast food sales.

B) High income countries showed most increase in fast food sales.

C) The high income countries saw the lowest increase in fast food sales.

D) The countries showing decreased wealth did not show an increase in fast food sales.

E) countries showing increased fast-food sales also showed increasing wealth.

29. Select the best word to insert in the blank space below:

"The _____ changes are of gross domestic product (per capita) and in total price paid by consumers."

A) overall

B) country

C) wealth

D) fast food sales

E) percent

30. Which one of these topics is graph 13 not linked to?

- A) Glocal foods
- B) Obesity
- C) Health
- D) Income
- E) Nutrition

Questions 31-35 refer to the following Web page and e-mail.

<http://www.Hardewickes.co.uk>

 **Hardewicke's**
The finest musical treasures in London!

Explore and take home some of London's rich history. The artifacts are a window into the creative minds that make up London's musical spirit.

Our collection spans musical genres from rock and roll to opera, highlighting England's great artistic contributors. The store features artists from the 1800s to rising stars seen on television today.

Click on the links below to view some of our current products. Electronic checkout is available.

[Records, CDs, Tapes; £10 and up](#)

[Songbooks, signed first-edition books; £15 and up](#)

[Apparel; £30 and up](#)

[Original artwork; £50 and up](#)

[Instruments; £100 and up](#)

We have even more in our shop, and the best pieces are often bought before they make it to the Web site! For the full experience, please visit us.

From:	Sophie Calvert
To:	Hardewickes@londonloc.co.uk
Re:	Mark Peckham Item
Date:	February 1

To Whom It May Concern:

I have a guitar that was previously owned by Mark Peckham. I found your Web site and thought that Hardewicke's might be interested in purchasing it for resale.

The guitar was custom-made for Mr. Peckham by his close friend Elizabeth Dangerfield to celebrate the successful release of his first album. He took it on tour with him around the country as well as abroad. The guitar was purchased by my father at a charity auction hosted by Mr. Peckham 20 years ago.

Please let me know what your purchasing procedures are and whether you buy items up front or take a percentage of the transaction when you resell the item.

Thank you,

Sophie Calvert

Turn to the next page

9

- 31 What is NOT suggested about Hardewicke's?
- (A) It has items from many different years.
 - (B) Its products represent numerous types of music.
 - (C) It guarantees the lowest prices on records and songbooks.
 - (D) It features products from English musicians.
- 32 What is indicated about Hardewicke's?
- (A) It was started by a musician.
 - (B) It plans to host a performance by Mr. Peckham.
 - (C) It advertises at concerts.
 - (D) It sells items directly from its Web site.
- 33 What is the lowest price Ms. Calvert's item would most likely sell for at Hardewicke's?
- (A) £10
 - (B) £30
 - (C) £50
 - (D) £100
- 34 What is suggested about Ms. Calvert?
- (A) She saw Mr. Peckham perform in England.
 - (B) She owns an item made by Ms. Dangerfield.
 - (C) She has previously worked with Hardewicke's.
 - (D) She would like to make a donation to her father's charity.
- 35 What does Ms. Calvert ask about?
- (A) The price of an instrument she saw at the store
 - (B) The procedure for renting a concert space
 - (C) The process for selling items to Hardewicke's
 - (D) The history of an item she wants to purchase

Turn to the next page

Questions 36-40 refer to the following list, schedule, and e-mail.

Books by James Trozelli



The History of Jeans

Where did it all begin? Trozelli visually chronicles the evolution of jeans through the centuries, from working wear to high fashion.

Look Past the Runway

Trozelli captures the creative process of some of the top designers from New York City to Paris. Spanning almost twenty years, the book is filled with Trozelli's photographs and shows what goes on in fashion houses before designs are ready for the runway.

Growing Into Clothes: My Story

An amusing memoir about growing up in the fashion world. Trozelli writes about his unconventional upbringing in New York City with parents who began as fashion models before launching their own design label.

Yards of Talent: A Decade of Style

A collection of Trozelli's images spanning a decade of fashion and revealing what was in style, what was out of style, and then what was back in style again.

<http://www.btwradio.com>

[Home](#) [On-Air Schedule](#) [Audio Archive](#) [Sponsors](#)

BTW Radio

Evening Programming, September 23

6:00—*On the Table*
Host Amanda Fry talks about the latest super foods; what they are, what they offer, and how best to prepare them. Featured recipes will be available on our Web site after tonight's show.

7:00—*Candid Now*
Host Britta Jung interviews photographer and author James Trozelli about what prompted him to write his latest book about his childhood. He shares stories about what it was like to grow up in the world of fashion.

8:00—*Tech Talk*
Host Lewis Pierce focuses on the latest electronics. He discusses products that are really innovative and useful and identifies those that are not.

Turn to the next page

E-Mail Message	
To:	listenercomments@btwradio.com
From:	cogilvie@sunmail.net
Date:	September 24
Subject:	Radio Interview
<p>I discovered BTW Radio over 20 years ago and have been a regular listener of your evening programming for at least a decade. I just want to say how much I enjoy your newest offering. I've been interested by many of the authors that have been featured on the show so far, but last evening's guest was especially entertaining. I remember James from when he was a little boy. I worked with his parents when they lived in New York, and I recall seeing James in his parents' studio most days after he got out of school. I was surprised to learn that he has written about his childhood, and I look forward to reading his new book.</p> <p>Thank you for the excellent program.</p> <p>Calista Ogilvie</p>	

- 36 What is one common feature in all of Mr. Trozelli's books?
- (A) They contain fashion photographs.
 - (B) They focus on famous models.
 - (C) They are set in New York City.
 - (D) They follow events over multiple years.
- 37 What book did Mr. Trozelli discuss on BTW Radio?
- (A) *The History of Jeans*
 - (B) *Look Past the Runway*
 - (C) *Growing Into Clothes: My Story*
 - (D) *Yards of Talent: A Decade of Style*
- 38 What is indicated about *Candid Now*?
- (A) It is broadcast every morning at 7:00.
 - (B) It was recently added to BTW Radio.
 - (C) It is hosted by Amanda Fry.
 - (D) It was moved to a new time.
- 39 In the e-mail, the word "regular" in paragraph 1, line 1, is closest in meaning to
- (A) orderly
 - (B) typical
 - (C) frequent
 - (D) complete
- 40 What is probably true about Ms. Ogilvie?
- (A) She has worked in the fashion industry.
 - (B) She has interviewed Mr. Trozelli.
 - (C) She was featured on *Tech Talk*.
 - (D) She hosts a radio program.

QCM Physique/Electronique – InfoS1

Pensez à bien lire les questions ET les réponses proposées

Q41. L'abscisse curviligne élémentaire ds dans la base de Frenet (\vec{u}_T, \vec{u}_N) s'écrit :

a. $ds = R \cdot d\theta$

b. $ds = R \cdot \dot{\theta}$

c. $ds = a_n \cdot dt$

d. $ds = dV \cdot dt$

Q42. L'expression de la composante tangentielle de l'accélération est :

a. $a_T = \frac{d^2s}{dt^2}$

b. $a_T = \frac{d^2s}{dt^2}$

c. $a_T = \frac{ds^2}{dt^2}$

Q43. Quelle est la bonne proposition concernant le vecteur \vec{u}_N de la base de Frenet ?

a. $\vec{u}_N = \cos \theta \vec{u}_x + \sin \theta \vec{u}_y$

b. Le vecteur \vec{u}_N est colinéaire au vecteur vitesse $\vec{v}(t)$

c. $\vec{u}_N = R \frac{d\vec{u}_T}{ds}$

d. $\vec{u}_N = \frac{1}{R} \frac{d\vec{u}_T}{ds}$

Un point matériel décrit un cercle de centre O et de rayon R . Sa vitesse a pour norme $v(t) = v_0 t$.
(Questions 44 et 45)

Q44. Donner l'expression de l'abscisse curviligne $s(t)$, sachant que $s(t=0) = 0$

a. $s(t) = v_0 R t$

b. $s(t) = \frac{v_0 t^2}{2}$

c. $s(t) = v_0 \left(\frac{t}{2}\right)^2$

d. $s(t) = -2Rv_0 t^2$

Q45. Exprimer les composantes a_T et a_N du vecteur accélération en base de Frenet.

a. $a_T = v_0 ; a_N = \frac{v_0^2}{R}$

b. $a_T = v_0 ; a_N = \frac{(t \cdot v_0)^2}{R} \times \vec{u}_N$

c. $a_T = \frac{v_0 t^2}{2} ; a_N = \frac{v_0^2}{R} t^2$

d. $a_T = -v_0 ; a_N = \frac{(t \cdot v_0)^2}{R}$

Soit le circuit ci-contre (Q46&47) :

Q46. Que vaut la tension U_3 ?

- a. 6 V
- b. 10,8 V
- c. -1,2 V
- d. 1,2 V

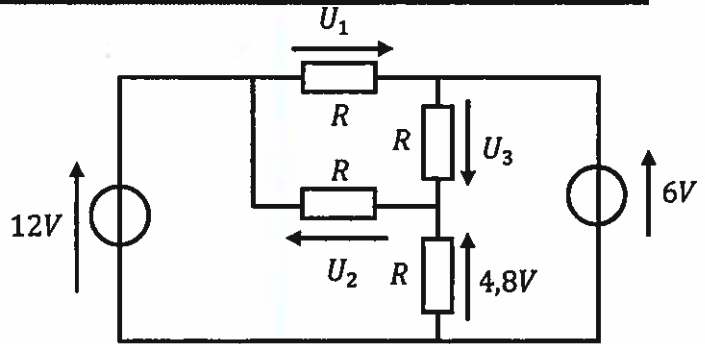

Q47. Que vaut la tension U_2 ?

- a. 6 V
- b. -6 V
- c. 7,2 V
- d. 13,2 V

On considère les 2 circuits suivants :

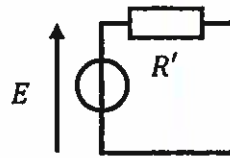
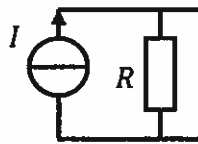

Ces 2 circuits sont équivalents si et seulement si :

Q48. $E =$

- a. I
- b. $R \cdot I$

- c. $\frac{R' \cdot R}{R+R'} \cdot I$
- d. Aucune de ces réponses

Q49. $R' =$

- a. R
- b. $\frac{R \cdot R'}{R+R'}$

- c. $\frac{R}{R+R'}$
- d. Aucune de ces réponses

Q50. On considère les 2 circuits suivants :

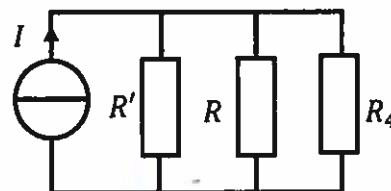
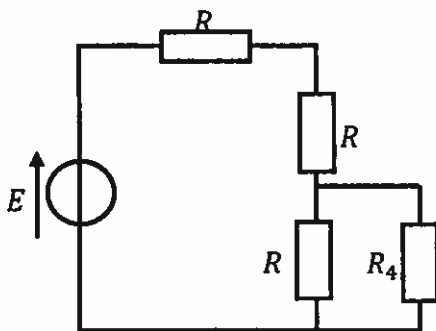

Ces 2 circuits sont équivalents si et seulement si :

- a. $I = 2R \cdot E$ et $R' = 2R$
- b. $I = \frac{E}{2R}$ et $R' = 2R$

- c. $I = \frac{E}{R}$ et $R' = R$
- d. $I = R \cdot E$ et $R' = R$

QCM 6

Architecture des ordinateurs

Lundi 6 décembre 2021

Pour toutes les questions, une ou plusieurs réponses sont possibles.

11. $A + \overline{A}.B =$

- A. Aucune de ces réponses.
- B. \overline{A}
- C. A
- D. $\overline{A}.B$

12. $\overline{A \oplus B} =$

- A. $\overline{A}.B + A.\overline{B}$
- B. $\overline{A \oplus B}$
- C. $\overline{A}.B + A.B$
- D. $\overline{A \oplus \overline{B}}$

13. $X = A.B.C + A.B.D + \overline{A}.B.C$

- A. X est une seconde forme canonique.
- B. X est une somme de produits.
- C. Aucune de ces réponses.
- D. X est une première forme canonique.

14. $X = (A + B + C).(A + B + D).(\overline{A} + B + C)$

- A. X est une première forme canonique.
- B. X est une seconde forme canonique.
- C. Aucune de ces réponses.
- D. X est une somme de produits.

15. $X = A.B + \overline{A}.B + \overline{A}.\overline{B}$

- A. X est une première forme canonique.
- B. X est une seconde forme canonique.
- C. Aucune de ces réponses.
- D. X est une somme de produits.

16. $(A + B).(A + \bar{B}).(\bar{A} + \bar{B}) =$

- A. $\bar{A}.\bar{B}$
- B. $A.\bar{B}$
- C. $\bar{A}.B$
- D. Aucune de ces réponses.

17. $\bar{A}.\bar{B}.C + \bar{A}.B.\bar{C} + \bar{A}.B.C + A.\bar{B}.C + A.B.\bar{C} =$

- A. $(A + B + C).(A + B + C).(A + B + C)$
- B. $(A + B + C).(A + \bar{B} + \bar{C}).(\bar{A} + \bar{B} + \bar{C})$
- C. $(\bar{A} + \bar{B} + C).(\bar{A} + B + \bar{C}).(\bar{A} + B + C).(A + \bar{B} + C).(A + B + \bar{C})$
- D. Aucune de ces réponses.

18. Dans un tableau de Karnaugh :

- A. Tous les 1 doivent être encadrés.
- B. Le nombre de 1 encadrés peut être impair.
- C. Aucun 0 ne doit être encadré.
- D. Aucune de ces réponses.

19. Dans un tableau de Karnaugh :

- A. Le nombre de cercles doit être minimum.
- B. Le nombre de cercles doit être maximum.
- C. La taille d'un cercle doit être minimum.
- D. La taille d'un cercle doit être maximum.

20. Dans un tableau de Karnaugh, le nombre de cercles correspond :

- A. Au nombre de termes de l'expression booléenne.
- B. Au nombre de variables non complémentées de l'expression booléenne.
- C. Au nombre de variables complémentées de l'expression booléenne.
- D. Aucune de ces réponses.