

ALGO
QCM

1. La méthode de recherche la plus naïve est la recherche ?
 - (a) séquentielle
 - (b) dichotomique
 - (c) autoadaptative
 - (d) par interpolation

2. Dans le cas d'un ajout d'un élément appartenant déjà à un ensemble, la solution retenue ?
 - (a) générera une erreur
 - (b) supprimera cet élément
 - (c) ajoutera un autre élément
 - (d) ajoutera l'élément une deuxième fois
 - (e) ne fera rien

3. Lors d'une recherche si la clé recherchée est trouvée, on parle de recherche ?
 - (a) négative
 - (b) positive
 - (c) affirmative
 - (d) logique
 - (e) cognitive

4. La complexité en moyenne de la recherche dichotomique positive est d'ordre ?
 - (a) linéaire
 - (b) logarithmique
 - (c) quadratique
 - (d) constant

5. la recherche autoadaptative est implémentable seulement sur ?
 - (a) liste triée croissante
 - (b) liste triée décroissante
 - (c) liste non triée

6. La complexité au pire de la recherche dichotomique négative est d'ordre ?
 - (a) linéaire
 - (b) logarithmique
 - (c) quadratique
 - (d) constant

7. La recherche dichotomique peut se faire sur ?
 - (a) liste triée croissante
 - (b) liste triée décroissante
 - (c) liste non triée

1

8. La recherche autoadaptative ramenant l'élément trouvé à la première place, préfère ?
- (a) une structure dynamique
 - (b) une structure statique
9. Quelle opération permet de récupérer le nombre d'occurrences d'un élément dans un multi-ensemble ?
- (a) count
 - (b) compte
 - (c) occ
 - (d) card
 - (e) nboccurrences
10. Un élément peut être présent plusieurs fois dans un ensemble ?
- (a) faux
 - (b) vrai

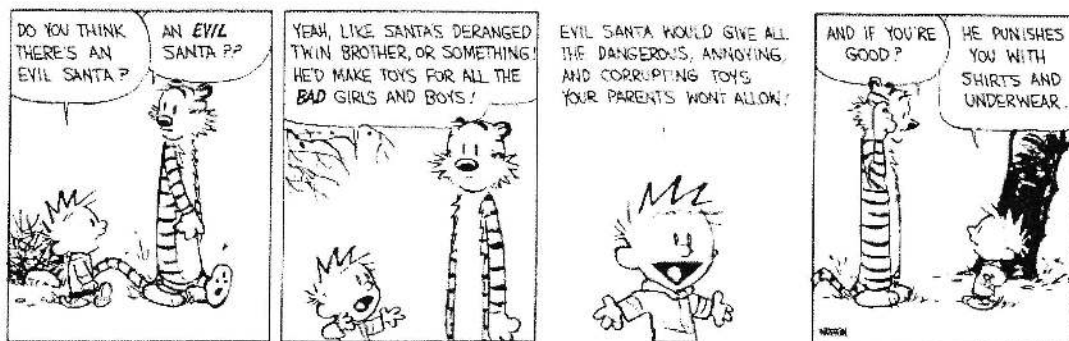

QCM N°14

lundi 11 décembre 2017

Pour tout $(a, b) \in \mathbb{N}^{*2}$, on note $a \wedge b$ le pgcd de a et b .

Question 11

Soit $P \in \mathbb{R}[X]$. On suppose que 2 est une racine double de P c'est-à-dire une racine d'ordre de multiplicité exactement égal à 2. Alors

- a. $(X - 2)^2$ divise P
- b. $P''(2) = 0$
- c. $P(2) = P'(2) = 0$ et $P''(2) \neq 0$
- d. $P(2) = P'(2) = P''(2) = 0$ et $P'''(2) \neq 0$
- e. rien de ce qui précède

Question 12

Soient $P \in \mathbb{R}[X]$, a et b deux racines de P avec $a \neq b$.

Alors P divise $(X - a)(X - b)$.

- a. vrai
- b. faux

Question 13

Soient $P(X) = X^2 + X + 1$ et $Q(X) = X + 1$. Alors

- a. $(P \circ Q)(X) = X^2 + X + 2$
- b. $(Q \circ P)(X) = X^2 + 3X + 3$
- c. $(P \circ Q)(X) = (Q \circ P)(X)$
- d. $d^\circ(P \circ Q) = d^\circ(Q \circ P)$
- e. rien de ce qui précède

Question 14

Soient P et Q deux polynômes quelconques non nuls de $\mathbb{R}[X]$.

- a. $d^\circ(P + Q) = d^\circ(P) + d^\circ(Q)$
- b. $d^\circ(P + Q) \leq \text{Max}(d^\circ(P), d^\circ(Q))$
- c. $d^\circ(PQ) = d^\circ(P) + d^\circ(Q)$
- d. Si $d^\circ(P) \neq d^\circ(Q)$ alors $d^\circ(P + Q) = \text{Max}(d^\circ(P), d^\circ(Q))$
- e. rien de ce qui précède

Question 15

Soient $P = X^4 - 3X^3 + 2X + 1$ et $Q = X^2 + 1$. Alors

- a. le quotient de la division euclidienne de P par Q est $X^2 - 3X - 1$.
- b. le quotient de la division euclidienne de P par Q est $X^2 - 3X + 2$.
- c. le reste de la division euclidienne de P par Q est $2X + 5$.
- d. le reste de la division euclidienne de P par Q est $5X + 2$.
- e. rien de ce qui précède

Question 16

Soient P et Q deux polynômes non nuls de $\mathbb{R}[X]$ tels que P divise Q et Q divise P . Alors

- a. $P = Q$
- b. il existe $\lambda \in \mathbb{R}^*$ tel que $P = \lambda Q$
- c. le reste de la division euclidienne de P par Q est 0
- d. rien de ce qui précède

Question 17

Soit $(a, b, c) \in \mathbb{N}^*{}^3$. Alors

- a. $a \mid b \implies a \mid bc$
- b. $[\forall (u, v) \in \mathbb{Z}^2, c \mid au + bv] \implies [c \mid a \text{ et } c \mid b]$
- c. $[c \mid a \text{ et } c \mid b] \implies [\forall (u, v) \in \mathbb{Z}^2, c \mid au + bv]$
- d. rien de ce qui précède

Question 18

Soit $(a, b) \in \mathbb{N}^*{}^2$ tel que $3a = 2b$. Alors

- a. $3 \mid b$
- b. a divise $2b$
- c. a divise b
- d. $a \wedge b = 1$
- e. rien de ce qui précède

Question 19

Soit $(a, b) \in \mathbb{N}^{*2}$ tel que $a \equiv 4[6]$ et $b \equiv 4[6]$. Alors

- a. $a + b \equiv 2[6]$
- b. $ab \equiv 4[6]$
- c. 6 divise $a - 4$
- d. rien de ce qui précède

Question 20

Soit $(a, b, c) \in \mathbb{N}^{*3}$. Alors

- a. Si $b \mid a$ et $c \mid a$, alors $bc \mid a$
- b. Si $b \mid a$ ou $c \mid a$, alors $bc \mid a$
- c. Si $bc \mid a$, alors $b \mid a$ et $c \mid a$
- d. rien de ce qui précède

21. The apartment was hot when I got home, so I _____ the air conditioner.

- a) had turned on b) have turned on c) turned on d) have been turning on

22. By the time Jason arrived to help, we _____ moving everything.

- a) finished b) had finished c) have finished d) finishing

23. My parents _____ the apartment for more than ten years.

- a) have been owning b) is been owning c) have owned d) have being owned

24. I _____ Prof. Blonsky for a long time.

- a) have been knowing b) know c) have knowed d) have known

25. Right now we _____ a cold wave. The temperature _____ very low lately.

- a) are having, has been b) have, is c) are having, is been d) have, has been

26. Fish were among the earliest forms of life. Fish _____ on earth for ages and ages.

- a) existed b) are existing c) exist d) have existed

27. After ten unhappy years, Jane finally quit her job. She _____ along with her boss for a long time before she finally decided to look for a new position.

- a) didn't get b) hasn't been getting c) isn't getting d) hadn't been getting

28. On a typical day, the average person _____ about 48,000 words. How many words did you speak today?

- a) spoke b) is speaking c) speaks d) was speaking

29. A: Is it true that spaghetti didn't originate in Italy?

B: Yes. The Chinese _____ spaghetti dishes for a long time before Marco Polo brought it back to Italy.

- a) Have been making b) made c) had been making d) have made

30. Jim, why don't you take some time off? You _____ too hard lately. Take a short vacation.

a) worked

b) work

c) were working

d) have been working

Should Facebook Manipulate Users?

By JARON LANIER JUNE 30, 2014

1. SHOULD we worry that technology companies can secretly influence our emotions? Apparently so.
2. A study recently published by researchers at Facebook and Cornell suggests that social networks can manipulate the emotions of their users by tweaking what is allowed into a user's news feed. The study, published in the Proceedings of the National Academy of Sciences, changed the news feeds delivered to almost 700,000 people for a week without getting their consent to be studied. Some got feeds with more sad news, others received more happy news.
3. The researchers were studying claims that Facebook could make us feel unhappy by creating unrealistic expectations of how good life should be. But it turned out that some subjects were depressed when the good news in their feed was suppressed. Individuals were not asked to report on how they felt; instead, their writing was analyzed for vocabulary choices that were thought to indicate mood.
4. The researchers claim that they have proved that "emotional states can be transferred to others via emotional contagion, leading people to experience the same emotions without their awareness." The effect was slight, but imposed on a very large population, so it's possible the effects were consequential to some people. The paper itself states its claims rather **boldly**, but one of the authors, Adam D. I. Kramer of Facebook, responding to intense criticism that it was wrong to study users without their permission, has since emphasized how tiny the effects were. But however the results might be interpreted now, they couldn't have been known in advance.
5. The manipulation of emotion is no small thing. An estimated 60 percent of suicides are preceded by a mood disorder. Even mild depression has been shown to increase the risk of heart failure by 5 percent; moderate to severe depression increases it by 40 percent.
6. Research with human subjects is generally governed by strict ethical standards, including the informed consent of the people who are studied. Facebook's generic click-through agreement, which almost no one reads and which doesn't mention this kind of experimentation, was the only form of consent cited in the paper. The subjects in the study still, to this day, have not been informed that they were in the study. If there had been federal funding, such a complacent notion of informed consent would probably have been considered a crime. Subjects would most likely have been screened so that those at special risk would be excluded or handled with extra care.
7. To promote the relevance of their study, the researchers noted that emotion was relevant to human health, and yet the study didn't measure any potential health effects of the controlled manipulation of emotions.
8. It is unimaginable that a pharmaceutical firm would be allowed to randomly, secretly sneak an experimental drug, no matter how mild, into the drinks of hundreds of thousands of people, just to see what happens, without ever telling those people. Imagine a pharmaceutical researcher saying, "I was only looking at a narrow research question, so I don't know if my drug harmed anyone, and I haven't bothered to find out." Unfortunately, this seems to be an acceptable attitude when it comes to experimenting with people over social networks. It needs to change.
9. Our laws require that cars be recalled and fixed even if a defect would be likely to injure only a very small number of people. In this case, we're talking about a study that was actually intended to cause a negative effect in many people, and one open question is how destructive it was in the worst instances that might have occurred.

10. All of us engaged in research over networks must commit to finding a way to modernize the process of informed consent. Instead of lowering our standards to the level of unread click-through agreements, let's raise the standards for everyone.
11. Now that we know that a social network proprietor can engineer emotions for the multitudes to a slight degree, we need to consider that further research on amplifying that capacity might take place. Stealth emotional manipulation could be channeled to sell things (you suddenly find that you feel better after buying from a particular store, for instance), but it might also be used to exert influence in a multitude of other ways. Research has also shown that voting behavior can be influenced by undetectable social network maneuvering, for example.
12. The principle of informed consent in the age of social networking can't be limited to individuals who are studied; the public has every right to be informed of otherwise undetectable commercial or political practices that are made possible by the results of research into high-tech manipulation, and to choose whether to give consent.
13. My guess is that the public would choose to outlaw using our communication tools as conduits for secret, algorithmic manipulations of our emotions.
14. Let us choose to live in a society of true hearts, not calculated ones.

Turn to the next page for the questions about this article

31. Which statement is true?
- Facebook studied their user's mood change in order to offer them better advertising.
 - Facebook directed the study on their own without anyone's consent.
 - Cornell researchers found out about Facebook's research and warned people about it.
 - None of the above.
32. Which statement is true?
- Messages were scanned for mood indicators.
 - Facebook asked people to mention in their messages how they felt.
 - Only unhappy people were subject to the study.
 - Only happy people were subject to the study.
33. Which statement is true?
- Researchers suggest that emotions are contagious between one another.
 - The majority of suicides are due to mood disorder.
 - Emotions and depression are very closely linked.
 - All of the above.
34. What does the highlighted word "**boldly**" in the text suggest?
- That the paper was written rapidly without any real findings.
 - That most researchers were not involved in the study.
 - That the paper's results were announced with confidence and courage.
 - That the results of the paper are totally wrong.
35. The writer suggests that:
- Facebook could not have told the subjects about the study.
 - Due to ethical standards, subjects should have been informed of the study.
 - It is the law to inform the general public about any kind of study.
 - All is ok because everything is mentioned in the generic click-through agreement.
36. Which statement is true?
- The writer suggests that Facebook alone need not respect the principle of informed consent.
 - The writer suggests that Facebook influences other companies to do the same kind of research.
 - Facebook is being singled out by the writer as the only network to organize that kind of study.
 - None of the above.
37. What did the writer suggest the researchers should have done with their study?
- Researchers should have measured the social impact of their study.
 - Researchers should have limited their study to emotionally unstable subjects.
 - Researches should have measured the impact of their study on subjects' health.
 - None of the above.
38. Which phrase is similar in meaning to the expression "**to bother to do something**" used in paragraph 8?
- To take the trouble to do something.
 - To carefully try something.
 - To show no concern about something.
 - A and B
39. What is the writer's wish?
- That Facebook face all charges held against it.
 - That all researchers work towards a better process of informed consent.
 - That Facebook get rid of the basic click-through agreement.
 - All of the above
40. The writer believes that this study could be used for...
- manipulating emotion to help financial transactions.
 - manipulating emotion to help understand people's social needs.
 - A and B
 - None of the above

Q.C.M n°8 de Physique

41- Le moment du poids dans le pendule simple (rotation autour d'un axe perpendiculaire à la feuille et passant par le point O) est :

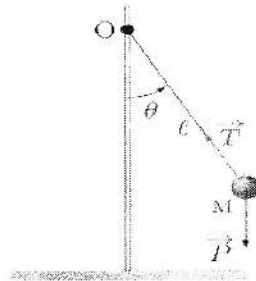

- a) $-P \cdot \ell$ b) nul c) $-P \cdot \ell \cdot \cos(\theta)$ d) $-P \cdot \ell \cdot \sin(\theta)$

42- La deuxième loi de Newton s'écrit comme :

- a) $\sum \vec{F}_{ext} = m \cdot \frac{d\vec{OM}}{dt}$
b) $\sum \vec{F}_{ext} = \frac{d\vec{p}}{dt}$
c) $\sum \vec{F}_{ext} = m \cdot \vec{V}$
d) $\sum \vec{F}_{ext} = m \cdot \frac{d^2\vec{V}}{dt^2}$

43- Donner un exemple de force à distance

- a) la force de rappel
b) l'interaction électrostatique
c) une réaction à une action

44- Qu'appelle-t-on une force de contact ?

- a) une force de répulsion entre deux corps
b) la poussée d'Archimède
c) une réaction à une action de type contact

45- Qu'est-ce qu'une force de rappel ?

- a) une force qui s'oppose au déplacement
b) une force de frottement
c) une force qui accompagne le mouvement

46- La deuxième loi de Newton appliquée à un pendule simple, qui oscille sans frottement, et projetée sur l'axe tangentiel de la base de Frenet donne :
(On suppose le mouvement vers la droite).

- a) $-P \cdot \sin(\theta) = ma_T$
- b) $T - P \cdot \sin(\theta) = ma_T$
- c) $T - P \cdot \cos(\theta) = ma_T$

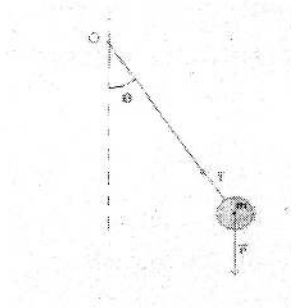

47- Dans le cas du pendule simple (question 46), la tension du fil T a pour expression :

- a) $T = m \frac{dV}{dt} + P \cdot \cos(\theta)$
- b) $T = m \frac{V^2}{R} + P \cdot \cos(\theta)$
- c) $T = m \frac{V^2}{R} + P \cdot \sin(\theta)$

48- Le travail d'une force \vec{f} de norme variable et qui fait un angle α avec le vecteur déplacement $d\vec{l}$ sur le trajet AB est :

- a) $W_{AB}(\vec{f}) = \int_A^B f \cdot dl \cdot \sin(\alpha)$
- b) $W_{AB}(\vec{f}) = \int_A^B f \cdot dl \cdot \cos(\alpha)$
- c) $W_{AB}(\vec{f}) = f \cdot AB \cdot \cos(\alpha)$

49- La définition de l'énergie potentielle élémentaire dE_p est :

- a) $dE_p = -\delta W(\vec{f})$ (travail élémentaire de la force de frottements)
- b) $dE_p = -\delta W(\vec{f}^{noncons})$ (travail élémentaire d'une force non conservative)
- c) $dE_p = -\delta W(\vec{f}^{cons})$ (travail élémentaire d'une force conservative)

50- Le travail d'une force \vec{F} conservative est :

- a) dépendant du chemin suivi
- b) toujours négatif
- c) indépendant du chemin suivi
- d) toujours nul

QCM Electronique – InfoS1

Pensez à bien lire les questions ET les réponses proposées

Q1. Soit le circuit suivant : Ce circuit comprend

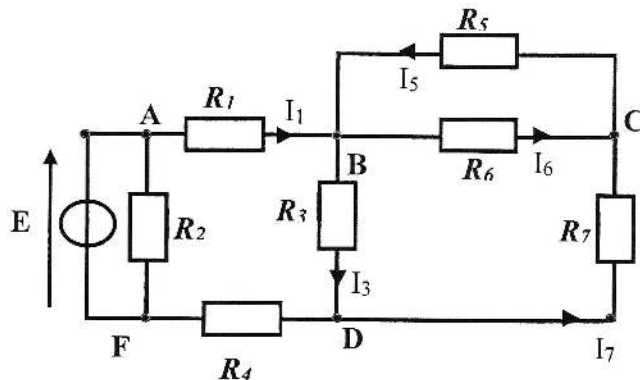

- a. 5 nœuds, 4 mailles
- b. 8 nœuds, 8 branches
- c. 5 nœuds, 8 branches
- d. Aucune de ces réponses

Q2. Une résistance court-circuitée a :

- a- une tension nulle à ses bornes
- b- un courant infini qui la traverse
- c- une tension infinie à ses bornes
- d- Aucune de ces réponses

Q3. L'application des théorèmes de superposition, de Thévenin et de Norton suppose qu'on annule des sources d'énergie.

Pour annuler une source de tension, il faut :

- a. Enlever la branche qui la contient
- b. La remplacer par un fil

Pour annuler une source de courant, il faut

- c. Court-circuiter ses bornes
- d. Enlever la branche qui la contient

Q4. Dans le théorème de Thévenin, la tension E_{th} du générateur est aussi appelée :

- a- La tension à vide
- b- La tension de court-circuit
- c- Aucune de ces réponses

Q5. Dans le théorème de Norton, le courant I_N du générateur est aussi appelé :

- a- Le courant à vide
- b- Le courant de court-circuit
- c- Aucune de ces réponses

Soit le circuit suivant avec $I_0, E_2, E_3, R_1, R_2, R_3, R_4$ supposés connus. (Q6&7)

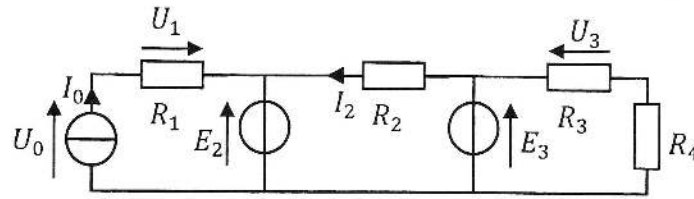

Q6. Quelle est l'affirmation vraie ?

- a- U_0 ne dépend pas de R_1
- b- I_2 ne dépend pas de R_3
- c- I_0 dépend de R_1
- d- $U_1 = R_1 \cdot I_0$

Q7. Que vaut I_2 si on conserve le générateur de tension E_2 , les autres générateurs étant annulés ?

- a. $I_2 = 0$
- b. $I_0 = R_2 \cdot E_2$
- c. $I_2 = -\frac{E_2}{R_2}$
- d. $I_2 = \frac{E_2}{R_2}$

Soit le circuit ci-contre (Q8 à Q10) :

Q8. Le courant I_1 est égal à :

- a. $\frac{V_0}{R_1 + R_2}$
- b. $\frac{V_2}{R_2}$
- c. $I_3 + \frac{V_3}{R_3}$
- d. $I_3 + \frac{V_3}{R_4}$

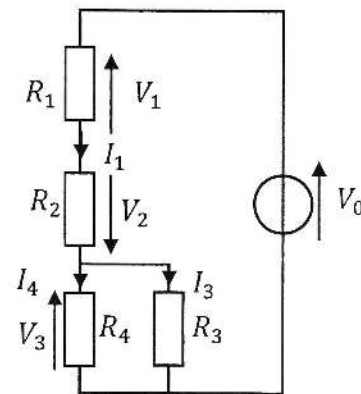

Q9. La résistance de Thévenin vu par R_4 est :

- a. $R_{th} = \frac{R_1 \cdot R_2 \cdot R_3}{R_1 \cdot R_2 + R_1 \cdot R_3 + R_2 \cdot R_3}$
- b. $R_{th} = \frac{(R_1 + R_2) \cdot R_4}{R_1 + R_2 + R_4}$
- c. $R_{th} = \frac{(R_1 + R_2) \cdot R_3}{R_1 + R_2 + R_3}$
- d. $R_{th} = R_1 + R_2 + \frac{R_3 \cdot R_4}{R_3 + R_4}$

Q10. La source idéale de courant du générateur de Norton vu par R_3 délivre un courant d'intensité :

- a. $I_N = \frac{V_0}{R_1 + R_2}$
- b. $I_N = \frac{V_0}{R_1 + R_2 + R_4}$
- c. $I_N = \frac{V_0 \cdot (R_3 + R_4)}{(R_1 + R_2) \cdot (R_3 + R_4) + R_3 \cdot R_4}$
- d. $I_N = \frac{V_0}{R_1 + R_2 + R_3}$

QCM 8

Architecture des ordinateurs

Lundi 11 décembre 2017

11. $\frac{(2^8 \cdot 4^{-10}) \cdot 128^{-3}}{(4^{-2} \cdot (2^4 - 2^3))^3 \cdot 64^{-5}} =$
- A. 512
 - B. 1
 - C. 2^{-42}
 - D. 0,25
12. En supposant que $16_b = 40_4$, quelle est la valeur de la base b ?
- A. Impossible
 - B. 8
 - C. 9
 - D. 10
13. $B2A_{16} + A0C_{16} + 10D2_{16} =$
- A. 3609_{16}
 - B. 3608_{16}
 - C. 2608_{16}
 - D. 2609_{16}
14. $11101001011_2 - 1111010100_2 =$
- A. 1001110111_2
 - B. 1101110111_2
 - C. 1100110111_2
 - D. 1011110111_2
15. Combien d'entiers signés peut-on coder sur n bits ?
- A. 2^n
 - B. $2^n - 1$
 - C. 2^{n-1}
 - D. $2^{n-1} - 1$

16. Soit l'addition sur 8 bits signés suivante : $150 + 105$
 Le résultat sur 8 bits signés est :
- 255
 - 1
 - 0
 - Cette addition n'est pas possible.
17. Une ou plusieurs réponses sont possibles :
 Soit l'addition sur 8 bits suivante : $01101100_2 + 01011001_2 = 11000101_2$
- Si les nombres sont non signés, il y a un dépassement non signé.
 - Si les nombres sont signés, il n'y a pas de dépassement signé.
 - Si les nombres sont non signés, il n'y a pas de dépassement non signé.
 - Si les nombres sont signés, il y a un dépassement signé.
18. Une ou plusieurs réponses sont possibles :
- $B.(\overline{A} + \overline{C}) + A.\overline{B}.C =$
- $B \oplus (A.\overline{C})$
 - $B \oplus (A.C)$
 - $B \oplus (\overline{A}.\overline{C})$
 - $B \oplus (\overline{A}.C)$
19. Dans un tableau de Karnaugh :
- Plus le nombre de bulles est petit, plus le nombre de variables dans un terme est grand.
 - Plus le nombre de bulles est petit, plus le nombre de termes de l'expression est grand.
 - Plus une bulle est petite, plus le nombre de variables dans le terme est grand.
 - Plus une bulle est petite, plus le nombre de termes de l'expression est grand.
20. $\overline{B}.\overline{C} + A.\overline{C} + \overline{A}.\overline{B} =$
- $\overline{B}.\overline{C} + A.\overline{C}$
 - $\overline{B}.\overline{C} + \overline{A}.\overline{B}$
 - $A.\overline{C} + \overline{A}.\overline{B}$
 - $A + \overline{B} + \overline{C}$