



Electronic Partial Review

*Calculators and documents are not allowed. The scale is indicative.
Answers exclusively on the subject. If you run out of space, you can use the back of the pages.*

Exercise 1. Course questions (6 points – no negative points for the MCQ)

Choose the correct answer:

Q1. To measure the current flowing through a generator, we place:

- a. A voltmeter in series with the generator
- b. An amperemeter in series after the generator
- c. A voltmeter in parallel with the generator
- d. An amperemeter in parallel with the generator

Q2. If we apply Ohm's law with U in volt (V) and I in milliampere (mA), we get directly R in:

- a. $M\Omega$
- b. $k\Omega$
- c. $m\Omega$
- d. Ω

Q3. What is the resistance seen between A and B?

- a. $15R$
- b. $\frac{28R}{33}$
- c. $\frac{R}{3}$
- d. $3R$

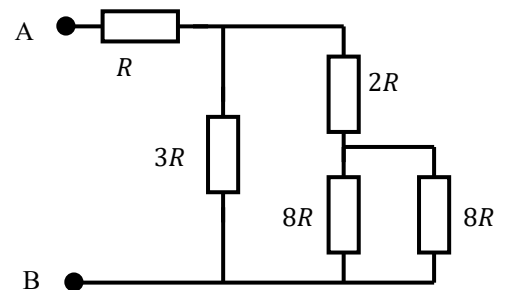

Consider the circuit opposite (Q4&5):

Q4. The voltage is: V_2

- a- Same sign as I_1
- b- From opposite sign to I_1
- c- From opposite sign to V_0
- d- Zero

Q5. The current is equal to: I_1

- a. $-\frac{V_0}{3R}$
- b. $\frac{V_2}{R}$
- c. $I_3 - \frac{V_3}{2R}$
- d. $\frac{V_0}{3R}$

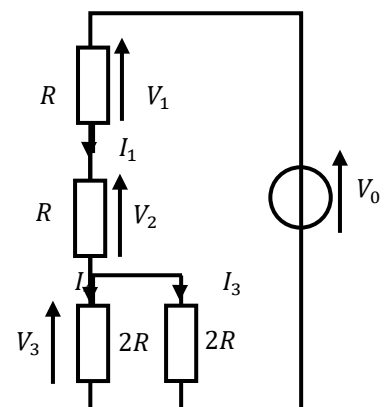

Q6. In the circuit opposite, what is worth U ?

- a. $2,5 V$
- b. $-2,5 V$
- c. $5V$
- d. $- 5 V$

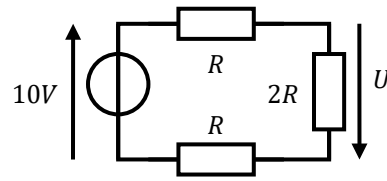

Q7. Consider the circuit opposite. What is the expression of intensity I' ?

- a- $I' = \frac{2}{7} \cdot I$
- b- $I' = \frac{1}{3} \cdot I$
- c- $I' = \frac{4}{7} \cdot I$
- d- $I' = \frac{2}{3} \cdot I$

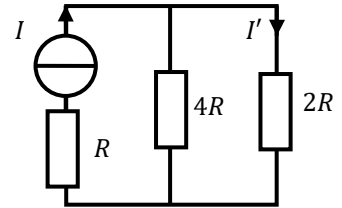

Q8. What is voltage worth U_1 ?

- a. $6 V$
- b. $-6V$
- c. $-18 V$
- d. $18 V$

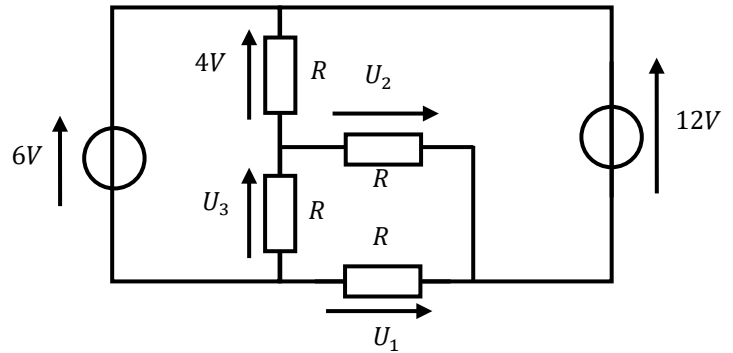

Exercise 2. Thévenin/Norton equivalences (14 points)

1. Consider the 2 circuits below:

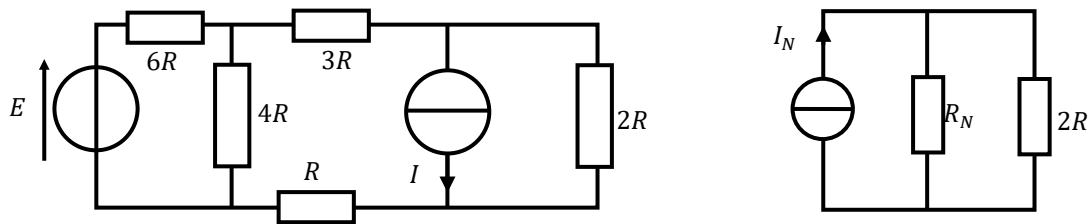

a. Determine the expressions of I_N and R_N such that the 2 circuits above are equivalent.

b. From this deduce the expression of the intensity I' of the current that crosses $2R$ as a function of E , I and R .

2. Consider the circuit opposite. Determine the expression of the tension U as a function of E , I and R . You can use the Thévenin/Norton equivalencies.

