

Final Exam S1

Computer Architecture

Duration: 1 hr. 30 min.

Last name: First name: Group:

Write answers only on the worksheet.

Do not show any calculation unless you are explicitly asked.

Do not use red ink.

Exercise 1 (2 points)

Convert the following numbers from the source form into the destination form. Do not write down the result in a fraction or a power form (e.g. write down 0.25 and not $\frac{1}{4}$ or 2^{-2}).

Number to Convert	Source Form	Destination Form	Result
101011101.0101	Binary	Decimal	
1E2.5	Hexadecimal	Decimal	
750	Decimal	Base 5	
1707.66	Hexadecimal	Base 8	

Exercise 2 (5 points)

Perform the following 8-bit binary operations (the two operands and the result are 8 bits wide). Then, convert the result into unsigned and signed decimal values. If an overflow occurs, write down 'ERROR' instead of the decimal value.

Operation	Binary Result	Decimal Value	
		Unsigned	Signed
10110111 + 00101101			
01011010 - 10001101			
01110111 + 11111000			
10000001 - 10000000			
11010111 - 01111100			

Exercise 3 (3 points)

We want to simplify the following circuit diagram:

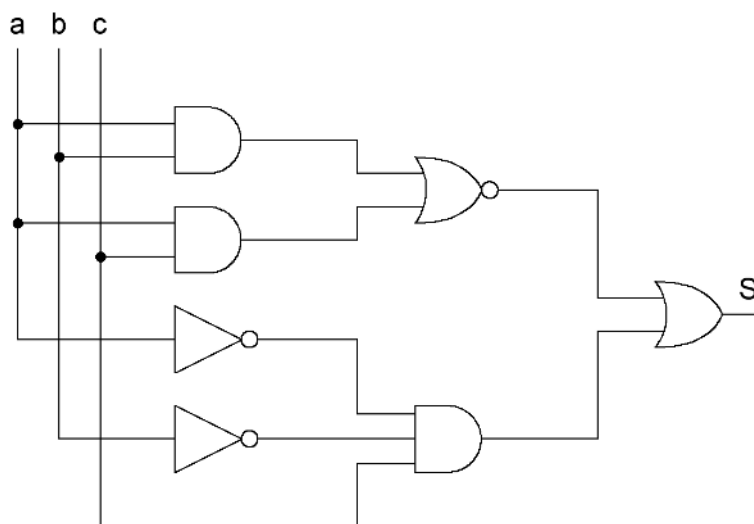

1. Without any simplifications, give the S output in terms of a , b and c .

$S =$

2. Give the most simplified expression of S .

$S =$

3. From the most simplified expression, draw a new circuit diagram by using three NOT gates, one two-input AND gate and one two-input OR gate.

Exercise 4 (4 points)

We want to design the following comparator:

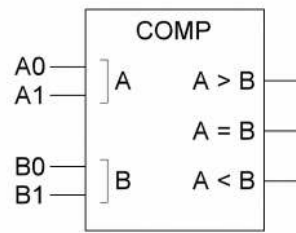

The A and B inputs are 2-bit unsigned integers ($A0$ and $B0$ are the LSBs):

- If $A > B$, the ' $A > B$ ' output is set to 1 and the other outputs are set to 0.
- If $A = B$, the ' $A = B$ ' output is set to 1 and the other outputs are set to 0.
- If $A < B$, the ' $A < B$ ' output is set to 1 and the other outputs are set to 0.

1. Complete the following truth table:

A1	A0	B1	B0	A > B	A = B	A < B
0	0	0	0			
0	0	0	1			
0	0	1	0			
0	0	1	1			
0	1	0	0			
0	1	0	1			
0	1	1	0			
0	1	1	1			
1	0	0	0			
1	0	0	1			
1	0	1	0			
1	0	1	1			
1	1	0	0			
1	1	0	1			
1	1	1	0			
1	1	1	1			

2. Without using Karnaugh maps, give the most simplified expression of the ' $A = B$ ' output. Use the **EXCLUSIVE-OR** operator to simplify the expression.

'A = B' =

3. Complete the Karnaugh maps below (circles included) and give the most simplified expressions of the ' $A > B$ ' and ' $A < B$ ' outputs. **No points will be given to an expression if its Karnaugh map is wrong.**

		B1 B0			
	A > B	00	01	11	10
A1 A0	00				
	01				
	11				
	10				

'A > B' =

		B1 B0			
	A < B	00	01	11	10
A1 A0	00				
	01				
	11				
	10				

'A < B' =

Exercise 5 (6 points)

Let us consider the truth tables below. A, B, C and D are the inputs. U, V, W, X, Y and Z are the outputs.

A	B	C	U	V
0	0	0	0	1
0	0	1	1	1
0	1	0	0	1
0	1	1	1	1
1	0	0	0	1
1	0	1	0	0
1	1	0	0	0
1	1	1	0	1

A	B	C	W	X
0	0	0	0	0
0	0	1	1	1
0	1	0	1	1
0	1	1	0	1
1	0	0	0	1
1	0	1	1	0
1	1	0	1	0
1	1	1	0	0

A	B	C	D	Y	Z
0	0	0	0	0	1
0	0	0	1	0	0
0	0	1	0	0	1
0	0	1	1	Φ	0
0	1	0	0	0	0
0	1	0	1	0	Φ
0	1	1	0	0	0
0	1	1	1	Φ	Φ
1	0	0	0	Φ	1
1	0	0	1	Φ	0
1	0	1	0	1	1
1	0	1	1	1	0
1	1	0	0	1	0
1	1	0	1	1	Φ
1	1	1	0	1	0
1	1	1	1	1	Φ

1. Write down the minterm canonical form of U .

$U =$

2. Write down the maxterm canonical form of V .

$V =$

3. Complete the Karnaugh maps below (circles included) and give the most simplified expression for each output. **No points will be given to an expression if its Karnaugh map is wrong. For the time being, do not simplify by using the EXCLUSIVE-OR operator.**

		BC				
		W	00	01	11	10
A	0					
	1					

$W =$

		C		
		X	0	1
AB	00			
	01			
	11			
	10			

$X =$

		CD				
		Y	00	01	11	10
AB	00					
	01					
	11					
	10					

$Y =$

		CD				
		Z	00	01	11	10
AB	00					
	01					
	11					
	10					

$Z =$

4. See if some of the W , X , Y and Z outputs can be simplified by using the EXCLUSIVE-OR operator. If so, simplify them and write down the new expressions (do not show any calculation).

Feel free to use the blank space below if you need to:

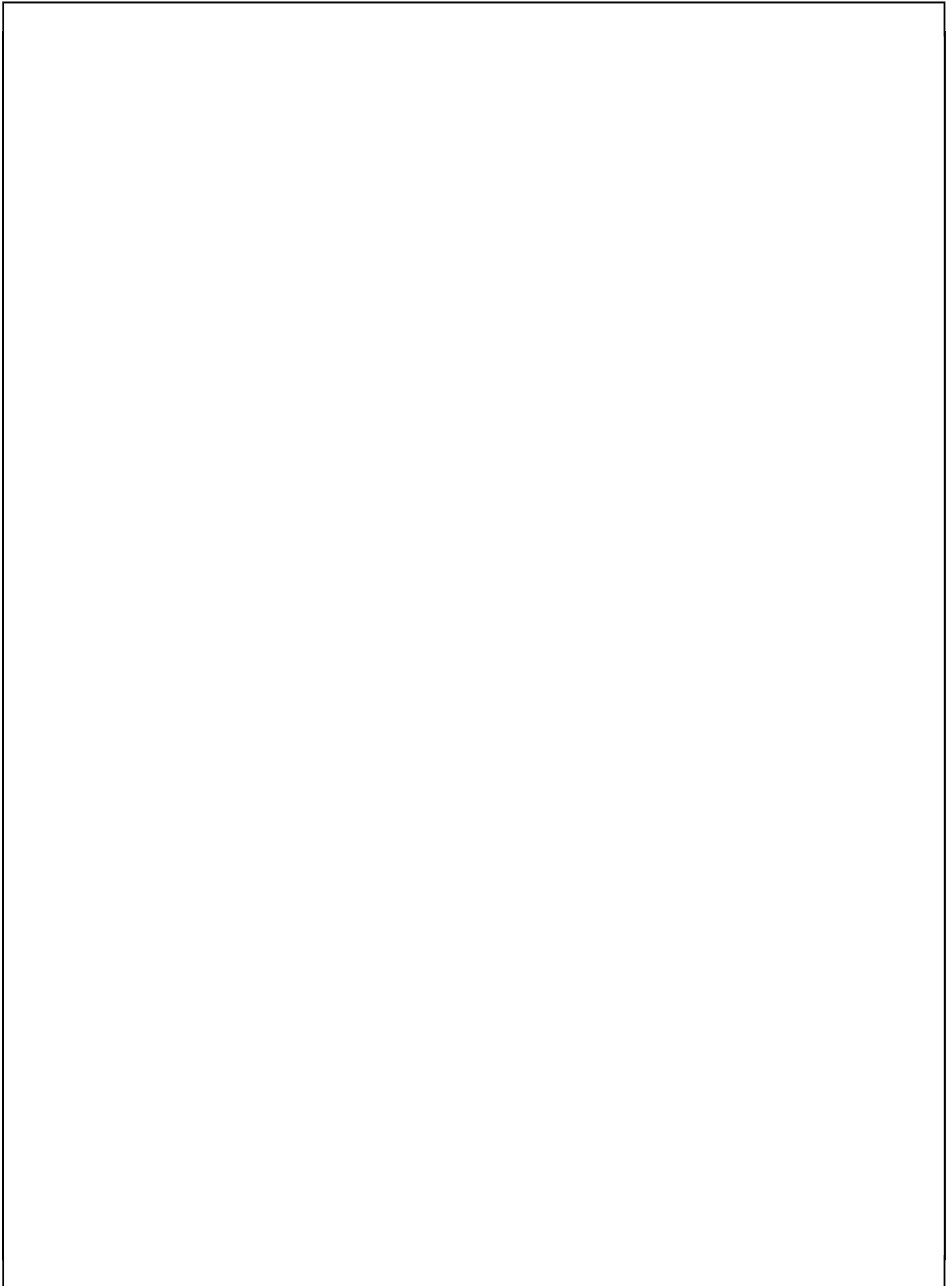
A large, empty rectangular box with a thin black border, occupying most of the page. It is intended for the student to provide answers or show work during the exam.